

# January, August & Final Reports

I-2001

## REPORTS

### Part 1 - Summary Details

Please use your TAB key to complete part 1 & 2.

CRDC Project Number: CSP98C

January Report:  Due 29-Jan-01  
August Report:  Due 03-Aug-01  
Final Report:  Due within 3 months of project completion

Project Title: Delivering to industry the benefits of cropping systems models

Project Commencement Date: 1-7-98 Project Completion Date: 30-6-01

Research Program: Farming Systems Agronomy

### Part 2 - Contact Details

Administrator: Mr Ken Parker, Laboratory Supervisor

Organisation: CSIRO Division of Plant Industry

Postal Address: Locked Bag 59, Narrabri, NSW 2390

Ph: 02 6799 1500 Fx: 02 6793 1186 E-mail: Ken.Parker@CSIRO.au

Principal Researcher: Mr Q.D. Richards

Organisation: CSIRO Plant Industry

Postal Address: Locked Bag 59, Narrabri, NSW 2390

Ph: 02 6799 1500 Fx: 02 6793 1186 E-mail: Dirk.Richards@CSIRO.au

Supervisor: Dr M.P. Bange

Organisation: CSIRO Plant Industry

Postal Address: Locked Bag 59, Narrabri, NSW 2390

Ph: 02 6799 1500 Fx: 02 6793 1186 E-mail: Michael.Bange@CSIRO.au

Supervisor 2: Dr. P.S. Carberry

Organisation: CSIRO Division of Sustainable Ecosystems

Postal Address: CSIRO Sustainable Ecosystems  
c/- Qld Dept of Primary Industry  
PO Box 102 Toowoomba QLD

Ph: 07 4688 1377 Fx: 07 4688 1193 E-mail: Peter.Carberry@CSIRO.au

Signature of Research Provider Representative: \_\_\_\_\_

## *Final Report*

---

### **1. Outline the background to the project.**

Profitability of cotton production is being threatened by resource limitations and reduced margins. The impact of agronomic decisions affect profitability and many of these decisions involve a degree of risk associated with factors such as rainfall variability. In many situations, history can serve as our best guide to the potential risks or benefits of a particular strategies. This knowledge can be tempered with local information to provide a basis for making informed decisions with a reasonable understanding of the risks and benefits. The use of crop models is an ideal and can be often the only way to address these sorts of issues.

This project primarily focused on identifying and researching the most appropriate means of delivering systems simulation to industry clients. CRDC project CSP67C identified that there was significant demand for cotton crop simulation/modelling, which CSP98C used as a catalyst for further research into applications of simulation. This research began to explore the application of modelling with irrigated growers, in particular focussing on water and nitrogen management. The key to having growers value crop simulations was the positioning of these simulations in the context of on-farm research, grower groups, soil characterisation, monitoring of crops, soil and climate and 'what-if' analysis sessions.

This project had 3 major components in delivering the results of systems simulation to industry.

1. Enhanced role of systems models - continue to explore the role of enhanced field monitoring and systems simulation in dryland and the expansion of work with commercial irrigated crops.
2. Assisting in the analysis of results from the CRC Farming Systems trials, and the extension of outcomes to the industry. Certain aspects of these trials are being recorded in order to provide information on systems sustainability, and it was hoped that systems simulation could be employed to assist in extending research results to other cropping regions and future seasons for the benefit of the broader cotton industry
3. Market research into innovative means of delivering systems simulations to industry clients, involving the development of a user-friendly version of OZCOT and a simulation capacity within the industry. Although the FARMSCAPE approach has been successful, this methodology is not sustainable because of the high cost of scientists being so closely associated with growers, advisers and the limited number of beneficiaries from such an association.

2. List the project objectives and the extent to which these have been achieved.

**Value of models** – Collaboration with a number of irrigated and dryland growers and their consultants in exploring the role for enhanced field monitoring and systems simulation in the management of dryland and irrigated cotton crops. Research strategies included:

- a. Identification of management issues to be addressed through participatory on-farm research and the application of systems models.

**Achievement:** management issues identified and 'needs' list for the Ozcot software compiled to enable these issues to be addressed. This is important for future development of the software and has uncovered novel applications.

- b. Expansion of the existing soil characterisation database and climate records to cover a broader range of cotton production regions;

**Achievement:** a total of 24 sites in NSW and QLD, situated on cotton growing soils, have been characterised to some degree for soil moisture capacity. These have been added to the database currently administered by APSRU. A significant outcome from this exercise has been increased understanding by growers about their soil and how to manage it more economically.

- c. Monitoring of soil water and nutrient status and crop management and performance within on-farm research trials;

**Achievement:** All trials monitored from sowing to harvest, and physiological measurements taken on many sites during the growing season. This information has enabled growers and researchers to examine and understand their crops response to environment and management, in greater detail than before.

- d. Analysis of on-farm trial results and the extension of insights to industry; and

**Achievement:** Without exposure of results to the wider industry, the benefits of grower/researcher interaction remains within the small grower groups. Therefore trial results have been presented at numerous industry forums and published in magazines and conference proceedings.

- e. Utilising simulation models directly with growers and consultants to benchmark crop performance and to explore alternative management options.

**Achievement:** Over 40 commercial cotton crops have been benchmarked over the past 3 years, both in irrigated and dryland production systems. This is important for model development but more significantly for grower confidence in the application of models to their farm. All growers involved have expressed confidence in Ozcot to simulate their cropping system.

**Simulating farming systems trials** – No thorough attempts at utilising models (APSIM and OZCOT) to interpret and extrapolate results collected from the CRC farming system trials have been undertaken. There are four main components to this part of the project:

- a. Collating and assessing information collected from CRC trials useful for simulation modelling.

**Achievement:** The majority of information for the Warra CRC trial site that was available has been collated and assessed. The collation process was lengthy and revealed many gaps in the collection process, highlighting the importance and use of clear protocols at trial inception.

- b. Model testing against actual datasets.

**Achievement:** Limited benchmark simulations have been completed, indicating confidence in the models but some concerns in the quality of data available of the Warra dryland trial.

- c. Assisting in the interpretation of trial results once confidence is established in the models ability to accurately simulate systems performance.

**Achievement:** It has been recognised that plant models could be used to address cropping systems questions. However better collection of data is required from systems trials to enable accurate simulation.

- d. Exploration of production strategies and performance of alternative cotton rotations over the long-term climatic record.

**Achievement:** Limited exploration of the CRC Farming Systems trial over the long term has occurred. Involvement with the CRC Farming Systems Scientist into production strategies, e.g. earliness, and trial work into alternative management issues, eg frequent irrigation, has occurred.

**Undertake research into the appropriate means of delivery of systems simulation to industry clients** – this part of the project involves researching alternative delivery techniques for simulation information to cotton industry clients using 2 approaches:

- a. Development and delivery of the OZCOT/CERCOT crop simulation model in a user-friendly form for use by industry clients.

**Achievement:** User-friendly version of Ozcot developed and distributed in February 2001 to Industry Development Officers and research staff. Growers exposed to software at subsequent meetings. Significant demand from other industry staff for access to Ozcot has followed from this release.

- b. The development and support of a simulation capacity within agribusiness and private consultancy services to enable provision of simulation services to their clients.

**Achievement:** The FARMSCAPE Accreditation Scheme was launched in 2000, involving 4 agribusiness firms and 2 other industry personnel. This scheme will develop a simulation capacity within the industry and provide understanding about applications and limitations of models. Dr Peter Carberry and Dr Michael Bange are part of the management panel. Dirk Richards has been trained through the accreditation scheme, and will apply similar techniques in the support of accredited users and Cotton CRC development Officers.

**3. How has your research addressed the Corporations three outputs: Sustainability, profitability and international competitiveness, and/or people and community?**

This research has addressed all three core areas for CRDC research. Efficiency of irrigation water and nitrogen fertiliser are just two elements that have been addressed within grower research groups with the use of the OZCOT cotton model. Growers and industry personnel have been provided with risk assessments of different cropping practices during the course of the project. Growers have used this information to make an educated decision of what crop to grow, how to best manage it and ultimately the most profitable for their situation. The maintenance of natural resources and profitable cotton growers will lead to sustainable rural communities, an aim which crop simulation can help to achieve.

**4. Detail the methodology and justify the methodology used.**

Recent efforts in applying cropping simulation models to commercial farm management have utilised participatory research approaches. FARMSCAPE (*Farmers, Advisers, Researchers, Monitoring, Simulation, Communication And Performance Evaluation*) is an acronym employed to represent the participatory action research approach that explicitly addresses the question of the relevance of systems models to commercial farming. This methodology revolves around working closely with growers and consultants on-farm, characterising soils for Plant Available Water Capacity (PAWC) for use in the cropping models, benchmarking particular crops and then using this information to make predictions of likely crop responses over longer climate histories. This approach has provided an excellent means for allowing farmers and advisers to become actively involved in the implementation of the research and interpretation of the outcomes. It has also provided the mechanism for all participants (including researchers) to learn more about their respective farming systems.

With the increase in demand for simulation generated information, the development of a user-friendly interface for Ozcot and the training in its use was considered to be of key importance. This development coincided with revision and refinement of the Ozcot software itself, incorporating changes and improvements that came out of the exploration of issues in the grower groups. Initial training in the use of Ozcot for the Industry Development Officers used aspects of the FARMSCAPE Accreditation approach, focussing on real applications of the model and hands-on use within a workshop environment.

Throughout the research project the Ozcot model has been used in two capacities. The stand alone version, both in the DOS environment and the user-friendly interface, has been widely used to address the majority of cotton crop management issues and questions. As a single crop model, Ozcot has the flexibility to simulate modern cotton production systems quickly and accurately. The previous CRDC funded project demonstrated that growers and advisers appreciated the simplicity of using the stand alone Ozcot and were confident in the results.

The Ozcot model is also a component of the APSIM multi-crop systems model, which CRU and ASPRU have shown to have applications within the cotton industry. It has been used to assess alternative cropping options in dryland production and to simulate crops such as sorghum being used as a trap crop for heliothis. This model also has the capacity to simulate irrigated systems, which allows simulation of the common cropping rotations within the Australian cotton industry.

### 5. Detail results including the statistical analysis of results.

Over the past 3 years of on-farm collaborations with irrigated and dryland cotton growers, until the 2000/2001 cotton season, over 40 benchmarking datasets have been collated and compared with Ozcot model predictions. A sub-set, up to the 1999/2000 season, of this comparison analysis is presented in Figure 1.

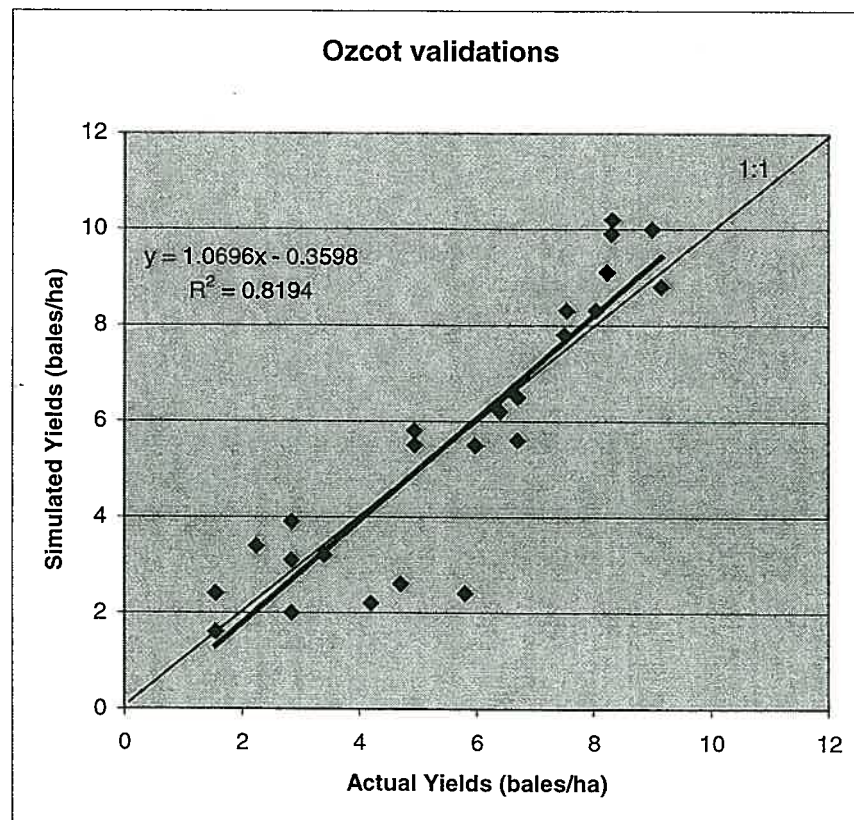

Figure 1. Ozcot stand-alone predicted yields vs actual yields for irrigated and dryland crops within NSW and QLD grower research groups.

Formal evaluations of group member attitudes during the project and at completion indicated that all had changed their attitude on soil moisture and nitrogen, with several indicating that in future they would be undertaking more soil sampling. Most growers were confident in the results that OZCOT produced and indicated a fair potential to change management decisions based on simulation results. The benchmarking exercise was highlighted as an important exercise, to give growers confidence in the relativeity of the Ozcot model to their farm and to explain their crops response to growing conditions during the seasons. Fruit counts conducted in the benchmarked fields, to allow comparisons between counts and simulated fruiting curves, indicated more research needs to be conducted into fine-tuning the Ozcot model for maturity and developing more stable varietal parameters. Simulation using patched analogous SOI phase climate data was also shown to be useful, giving growers a clearer picture about the seasons final yield and maturity date. This showed a great opportunity to include this feature in the re-development of HydroLOGIC, a water accounting and management program to be incorporated into CottonLOGIC. This initiative is presently being supported through other CRDC funded projects.

Ozcot and APSIM were used within the Farming Systems/Agronomy area and in collaboration with the CRC farming systems researchers during the life of the project, involving;

- Collection of data from the CRC Warra dryland site which was collated for inclusion into the APSIM model for benchmark simulations. This modelling indicated a fair ability to simulate the trial farming systems, and the results were presented at Farming Systems program meetings and the Farming Systems Forum at Dalby, in December 2000. These results are presented in Figure 2 and Appendix 1. A data framework is currently being developed to enable revised information to be incorporated into comparisons of actual vs simulated results.

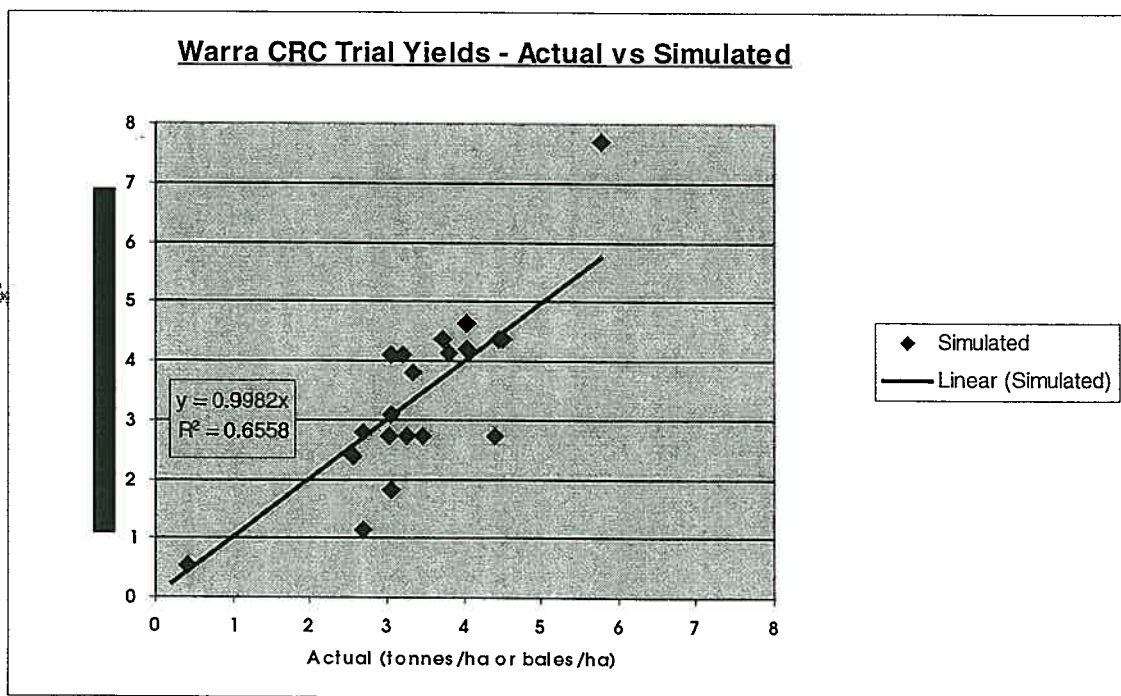

Figure 2. Warra trial simulation results.

- OZCOT model was used to benchmark earliness trials conducted during 1999/2000 at Goondiwindi, Boggabilla and Boggabri to assess different crop management techniques to promote earliness, and to test the accuracy of yield and maturity predictions. The model was then used to assess the implications of two management scenarios, applied crop nitrogen and last irrigation date, over a long-term climate record. The OZCOT model was shown to provide qualitative yield information on the effectiveness of a limited number of management strategies, but further work is needed to help refine the model ability to simulate crop maturity. This work has been reported in a paper entitled 'Assessing the risk of cotton 'earliness' management strategies with crop simulation' and was presented at the 10th Australian Agronomy Conference in Hobart, January 2001.
- Physiological investigations into the ultra narrow row production system, in collaboration with the Upper Namoi Industry Development Officer, Mark Hickman, were used to assess the ability of the Ozcot model to simulate this production system. Initial simulations showed the yield predictions to be close to actual, and although the results seem to be relatively insensitive to changes in plant population, this is probably more to do with how the model handles row spacing rather than plant population. It is an area for future development and refinement. The physiology information collected during the 1998/99 season was analysed and results were presented at the DeltaPine Ultra Narrow Row conference held in Dubbo on the 20<sup>th</sup> of August 1999.
- Collaborative research with two dryland growers James Clark, Alan Hunter, and with Michael Castor (consultant) into early season damage in double skip dryland crops at Croppa Creek. Subsequent monitoring of water extraction, weather, fruit retention and plant height were undertaken. Investigation of the impact of plant damage on this extraction capacity suggests that damage by thrips and *Helicoverpa* during early season plant growth may not limit the plants ability to exploit soil moisture at depth and in skip. Rather, that weather conditions experienced during crop growth will have a greater impact on the range of soil moisture extraction. The trial results provided a catalyst for the group to use modeling to examine the performance of their crops, reflecting on the weather conditions and resultant crop responses, and testing alternative management strategies. This research was published and presented at the 10<sup>th</sup> Australian Cotton Conference, Brisbane, August 2000. This work will also be used as an important dataset for validation of the model to handle crop compensation.
- Irrigation scheduling trials were established during 1999 and 2000, in collaboration with Auscott Narrabri, to assess the advantage of frequent irrigation to crop development and yield, and to assess the long term viability of the management option. Soil moisture information revealed significant time differences in saturated soil moisture conditions following irrigations, however physiological and yield results collected reveal no significant differences between the two irrigation treatments. Benchmark simulations using Ozcot show accurate predictions of soil moisture and fruiting dynamics, and longer term simulations (43 years) show a negative effect on final yield in most years and seasonal forecasts. This result influenced the growers decision to discontinue evaluating this system.

6. Discuss the results, and include an analysis of research outcomes compared with objectives.

**Value of models – Collaboration with growers and their consultants in exploring the role for enhanced field monitoring and systems simulation in the management of dryland and irrigated cotton crops:**

- Identification of management issues to be addressed through participatory on-farm research and the application of systems models;

**Outcome:** To facilitate the identification and investigation of management issues within the cotton industry, grower groups were formed in 1998, with 5 irrigated groups and 2 dryland groups in Qld and NSW. A total of 22 growers have been actively involved with these groups, however many other individual growers have assisted in this identification process through the exploration of management options on their own farms. Management issues and applications identified included:

Issues and applications identified by growers and consultants - in-season meetings discussed tactical applications of the model, such as first and last irrigation dates and predicted maturity. Some modelling was done to determine the likely impact of irrigating on a particular date during the season based on current crop and soil conditions. Winter meetings focussed on the benchmark simulation results for each grower field, comparisons with actual field data, plant responses to the climate and crop inputs. These simulations were a powerful tool to assess just what went wrong during the previous season and how certain crop responses could be avoided. Long term (1957-2000) simulations for the irrigated blocks were done, assessing the impact of different allocations and deficits on potential yield. This application is relevant with the restrictions on water extraction, and partial irrigators such as growers on the Darling Downs. Dryland growers were interested to assess the impact of different sowing dates and altered row configurations. Numerous consultations with the individual growers were also conducted, assessing tactical 'what-if' questions not addressed during group meetings.

Several growers highlighted that the greatest potential of the model is for in-season decision making, ie for irrigations, fruit development comparisons and inputting actual counts to the model, and in nitrogen management. Other simulations that could assist in crop management were variety comparisons, fibre quality, sowing soil moisture, and pre-irrigation vs water-up.

Issues and applications identified by Industry Development Officers and other extension staff – The Cotton CRC Industry Development Officers in the Upper Namoi, Gwydir, Macquarie, and Dawson-Callide valleys have been actively involved with the project over the past 3 years. As active participants in the grower groups they have helped in the exploration of model applications and individually by requesting

information about general crop performance in their district based on simulation results and the current seasonal forecast. Issues addressed have included reduced water allocations, frequency and timing of irrigations, and dryland summer cropping comparisons between cotton, sorghum and mungbeans.

Issues and applications identified by commercial companies and government departments - Requests for simulation information were received from representatives of CSD, Westfarmers landmark (formerly IAMA), Hassall and Associates, and numerous other independent consultants along similar topics to extension staff. The Ozcot model was used to simulate cotton yield for a range of water supply options per hectare for the Queensland Department of Natural Resources. Ozcot results and simulated streamflow data were linked to determine projected crop areas in each season and to determine economic value of management strategies.

- Expansion of the existing soil characterisation database and climate records to cover a broader range of cotton production regions;

**Outcome:** Soil characterisation for plant available water capacity (PAWC) was carried out on all farms within the growers groups, which are also characteristic of the general cotton growing regions. A total of 15 sites have been characterised in NSW, and 9 in QLD. This data has increased the accuracy of subsequent simulations and have also been entered into a soil database managed by APSRU. Contact was made with the project officer of a GRDC/NHT project, involving characterising major soil types within North-West NSW for PAWC, to enable information collected to augment and not duplicate existing data. The project officer has also contributed to the development of access to climate data for research applications through project CSP128C 'Enhancing access to climate and weather data'.

- Monitoring of soil water, nutrient status, crop management and performance within on-farm research trials;

**Outcome:** Before each cotton season all growers selected a field for further study, which were subsequently soil sampled to 1.8m depth prior to crop sowing, and analysed for nitrogen and soil moisture. These 'at sowing' results formed the basis of project work, with data used to initialise the model for subsequent simulation runs. Post harvest samples were also taken to assess the nitrogen uptake by the cotton crop and future management options. This monitoring operation improved the accuracy of the simulations but also provided key information to explain the crops response to management and weather conditions.

- Analysis of on-farm trial results and the extension of insights to industry;

**Outcome:** Where possible the results of research and the application of Ozcot have been published and presented to the industry at appropriate forums. By

involving Industry Development Officers within the grower groups, extension staff have experienced first hand the application of modelling to crop management. Within the research groups, growers and extension staff have helped in the exploration of model applications and individually by requesting information about general crop performance in their district based on simulation results and the current seasonal forecast. Extension staff were particularly interested in the yield potential of later sowings in northern NSW, and the impact of reduced water allocations and possible strategies to avoid yield reductions. These simulation 'insights' were published in regional newsletters (Cottontales) and seasonal trial booklets.

- Utilising simulation models directly with growers and consultants to benchmark crop performance and to explore alternative management options.

**Outcome:** Benchmarking the performance of models against measured crop yields and visa versa has been an important component of this research and was undertaken for two reasons. Firstly to establish model credibility and relevance to commercial farming systems, and secondly to assess the performance of crops at the end of the season with predicted potential yield. Generally the model has simulated crop yields well (Fig.1) and has proved credible enough to be relevant. As with past projects all growers involved have been enthusiastic to learn more about their soil resource and to use models to look at their crops performance. The maintenance of exposure and the increased exposure in areas not previously serviced over the past 3 years is a major outcome of this collaborative research project.

**Simulating farming systems trials** – No thorough attempts at utilising models (APSIM and OZCOT) to interpret and extrapolate results collected from the CRC farming system trials had been undertaken when this project was initiated. These models can potentially be used to ask important system viability questions over a longer time frames. There were four main components to this part of the project:

- a. Collating and assessing information collected from CRC trials useful for simulation modelling.

**Outcome:** Collating of relevant data from the Warra Farming System trial has taken considerable time, with time devoted to assessing the quality of data for inclusion in the benchmarking dataset. This dataset is now together in electronic and paper form and some attempt will be made to publish this information in the future.

- b. Model testing against actual datasets.

**Outcome:** Model validation has been carried out on several occasions when new data has become available. Reasonable yield accuracy has been achieved, although some rotations, notably wheat following cotton, have not been simulated well. Comparisons between actual nitrogen balance and simulated have been difficult because of few data points collected during the early years of the trial.

- c. Assisting in the interpretation of trial results once confidence is established in the models ability to accurately simulate systems performance.

**Outcome:** Interpretation of trial results has been limited due to confidence in the nitrogen balance simulations and time constraints.

- d. Exploration of production strategies and performance of alternative cotton rotations over the long-term climatic record.

**Outcome:** Time constraints have meant that exploration of dryland production strategies based on the Warra farming systems trial have not occurred. An important lesson has been learnt with regards to data collection and storage for future access and use. Protocols have been developed with the CRC Farming Systems Scientist to ensure that future farming systems research collect the appropriate data for use with cropping models.

**Undertake research into the appropriate means of delivery of systems simulation to industry clients** – this part of the project involves researching alternative delivery techniques for simulation information to cotton industry clients using 2 approaches:

- a. Development and delivery of the OZCOT/CERCOT crop simulation model in a user-friendly form for use by industry clients. Development of a user-friendly version will finally allow other researchers and extension officers personal access to cotton simulation models. Developing and evaluating this approach will use the groups established as part of the first component, in addition to the CRC Industry Development Officers and other extension staff.

**Outcome:** Development of the user-friendly OZCOT was achieved during the course of the project. An Ozcot training workshop was held on the 21<sup>st</sup> of February 2001, to give the Industry Development Officers and researchers an overview to Ozcot, how to run simulations and interpret the results, and some potential applications of the model. This version of Ozcot has also been used within the grower group meetings during 2001 to explore issues that were relevant. This exposure and use has produced a long list of improvements and development 'needs'.

- b. The development and support of a simulation capacity within agribusiness and private consultancy services to enable provision of simulation services to their clients.

**Outcome:** The APSIM Training, Accreditation and Licensing Program, which aims to investigate and evaluate the use of the FARMSCAPE with agribusiness, was launched in 2000. Four companies were selected and are now participating in the training and accreditation program. As part of this project, Dirk Richards of the Cotton CRC, has

been undergoing accreditation under the scheme, with the aim to provide these skills to the cotton industry. This work-based training will continue until 2003.

**7. Provide an assessment of the likely impact of the results and conclusions of the research project for the cotton industry. Where possible include a statement of the costs and potential benefits to the Australian cotton industry and future research needs.**

During the life of the project several evaluations have been done, to assess attitude change within each grower group and whether the broad project goals were being achieved. These revealed significant changes in fertiliser management were likely to occur following soil sample, a finer appreciation and understanding of the soil moisture profile, and the realisation that the Ozcot model was accurate in predicting aspects of their system. All project participants indicated they wanted to see more of the Ozcot model, and to use it to a greater degree in their on-farm crop decision making. These conclusions are mirrored by the industry at large, by comments and the demand from commercial and government departments for crop simulation information. This has been highlighted by strong industry support for HydroLOGIC development and the ongoing evolution of CottonLOGIC.

Future research needs have been highlighted during the life of this project, and include:

- Cotton fibre quality and the ability to simulate the effects on quality of different crop decisions.
- Refined varietal characteristics that simulate a wide range of growing locations and maturity.
- Soil characterisation information for all cotton growing regions, particularly in NSW growing areas.
- Simulation of growth under a variety of row spacing and plant population situations, especially ultra-narrow row cotton.

**8. Describe the project technology (eg. commercially significant developments, patents applied for or granted licenses etc).**

Ownership of the Ozcot cotton model remains with the Cotton Research Unit, CSIRO Division of Plant Industry.

Ownership of the APSIM cropping systems model remains with the Agricultural Production Systems Research Unit (APSRU), CSIRO Division of Sustainable Ecosystems.

APSRU and the CSIRO Cotton Research Unit, via GRDC and CRDC, are currently supporting four agribusiness consulting companies to become trained and

accredited in the application of soil monitoring, climate forecasting and simulation modelling to support farmers' learning, planning and decision-making in uncertain environments. The four companies selected are each contribute staff and funding to this FARMSCAPE training and accreditation program and are exploring commercial application of these tools.

**9. Provide a technical summary of any other information developed as part of the research project. Include discoveries in methodology, equipment design, etc.**

Not applicable

**10. Detail a plan for the activities or other steps that may be taken;**

A new project (CSP139C) is already underway, titled 'Application of crop simulation within the Australian Cotton Industry'. This project focusses on delivering simulation results to the cotton industry in a timely and efficient fashion through several avenues. CRDC project CSP98C identified that there was significant demand from growers and industry representatives for access to cotton simulations, and that this momentum must be maintained to enable the cotton industry to maximum benefit from this technology.

The new project has 3 key components in providing this simulation capacity to the cotton industry:

**1. Collaborative on-farm research involving investigations into applications of cotton modelling and delivery of simulation results.** This method of research has been shown to be extremely successful in positioning cropping simulation within the cotton industry, with growers and researchers combining soil characterisation, crop benchmarking, seasonal forecasting, and 'what if' sessions. A continuation of this research component will enable continued feedback and exploration of applications for simulation within dryland and irrigated cotton production regions, and assessment of delievery options.

**2. Meeting the industry demand for simulations.** Considerable time and effort would be required by researchers to enable site specific simulations for every farm within the Australian cotton industry, however two techniques will be utilised to address the industry demand.

**a) Provision of support services to the CRC Industry Development Officers and other industry pesonnel in the use of the Ozcot model.** Industry staff with access to the Ozcot model have some experience in the operation of the models and interpretation of results, however ongoing support and evaluation of its use is required to enable quality results to be disseminated to the industry.

**b) Maintenance of a simulation capacity and skills within the CRC and cotton industry to enable growers and industry representative to access this technology.** Both dryland and irrigated cotton growers have shown enthusiasm about cotton modelling and using this technology to help make

crop management decisions. This momentum developed over the past project must be maintained to ensure the industry receives the maximum benefit in the longer term. Other areas of important use are expansion into new cropping areas and alternative crop management techniques, such as frequent irrigation and UNR.

**3. Formalised accreditation in the FARMSCAPE participatory learning approach pioneered by APSRU**, in which growers, consultants and researchers conduct on-farm trials to link agronomy, crop management and simulation together to provide crop management strategies. These techniques will be used when working with industry staff and growers to allow rapid adoption of this technology.

In addition to this new project, other activities which have the potential to disseminate Ozcot simulation generated information and components of the FARMSCAPE approach within the industry are:

- Water use efficiency studies conducted by officers involved with the Water Use Efficiency Initiative in NSW and QLD.
- Other decision support system development activities, eg HydroLOGIC

#### **11. List the publications arising from the research project.**

Appendices 2 to 16 contain copies of the publications listed below.

##### *Submitted conference papers*

Bange, M.P., Carberry, P.S., and Richards, D. (1998) *Cropping systems models in the Australian cotton industry*. In Proc. of the Cropping Systems Forum, Narrabri, N.S.W. CRDC and CRC for Sustainable Cotton Production.

Richards, D., Bange, M.P., and Carberry, P.S. (1999). *Delivering to industry the benefits of cropping systems models*. In Proc. of the Cotton CRC Research Conference, Narrabri, N.S.W. CRDC and CRC for Sustainable Cotton Production.

Milroy, S.P. and Bange, M.P. (1999). *Agronomic research to support the development of crop simulation models*. In Proc. Cotton CRC Research Conf. 21-22 July, Narrabri Aust. Cooperative Research Centre for Sustainable Cotton Production, pp. 309-313.

Richards, D., Bange, B., and Wilson, L., (2000) *Early Season Insect Damage in Double Skip Cotton Crops*, Proceedings of the 10th Australian Cotton Conference, Brisbane August 2000.

Bange, M., Deutscher, S., Plummer, C., Larsen, D., Linsley, D., Richards, D., Whiteside, S. (2000) *Crop Models and Decision Support – Future Developments and Applications*, Proceedings of the 10th Australian Cotton Conference, Brisbane August 2000.

Richards, D.Q., Bange, M.P., and Roberts, G.N. (2001) *Assessing the risk of cotton 'earliness' management strategies with crop simulation*. In Proc. of the 10th Australian Agronomy Conference, Hobart, Tasmania.

### *Other publications*

Bange, M.P. and Carberry (1999). *Decision Tools for Crop Rotation and Management Systems*. In Proceedings of the GRDC Adviser Update Seminar. Gunnedah NSW. Grains Research and Development.

Bange, M., Carberry, P., and Hammer, G. (1999). *Seasonal climate forecasting for cotton management*. 20(3). The Australian Cotton Grower. pp. 36-42.

Richards, D., Bange, M.P., Dalgliesh, N.P., and Cawthray, S. (1999) *Monitoring nitrogen and soil water: Deep soil sampling benefits dryland cotton*, The Australian Cottongrower, Vol 20, No. 2, pp58-62.

Richards, D., Bange, M.P., and Cawthray, S. (1999) *Making more informed summer dryland cropping decisions*, The Australian Cottongrower, Vol 20, No. 5, pp26-29.

Richards, D., Bange, M.P., and Cawthray, S. (1999) *Northern Focus: What crop to grow this summer?*, Australian Grain, Vol 9, No. 4.

Richards, D., Bange, B., and Milroy, S. (1999) *Where did all the sunshine go?*, The Australian Cottongrower, Vol 21, No. 3, pp24-27.

Milroy, S., Bange, M.P., and Richards, D. (1999) *Cool Starts: What is normal?*, The Australian Cottongrower, Vol 21, No. 2, pp70-73.

Richards, D., Kelly, D., and Williams, T. (2000) *Using Ingard® Cotton in a Low Input Cotton System*, Central Queensland Cotton Trial Booklet, QDPI.

Richards, D., Cawthray, S., Bange, M.P., and Carberry, P.S. (2000) *Delivering to industry the benefits of cropping systems models*. Namoi Valley 2000 Field Day Booklet.

Richards, D.Q., Bange, M.P., and Milroy, S.P. (2001). *The 2000-01 season in review*. 22(3) The Australian Cottongrower pp.40-46.

## **12. Are changes to the Intellectual Property register required?**

No changes are required to the IP register.

## ***Part 4 – Final Report Plain English Summary***

---

Provide a half to one page Plain English Summary of your research that is not commercial in confidence, and that can be published on the World Wide Web.

This collaborative project involved using crop simulation models to assess the impact of decisions on crop and system performance. Two crop simulation models are being used in this research, OZCOT developed by CSIRO Cotton Research Unit at Narrabri, and APSIM (Agricultural Production Systems Simulator). FARMSCAPE (*Farmers, Advisers, Researchers, Monitoring, Simulation, Communication And Performance Evaluation*) is an acronym employed to represent the participatory action research approach that has been adopted for this research project. This methodology revolves around working closely with growers and consultants on-farm, characterising soils for Plant Available Water Capacity (PAWC) for use in the cropping models, benchmarking particular crops and then using this information to make predictions of likely crop responses over longer climate histories.

This project had three major components in delivering results of simulation to industry:

1. **Enhanced crop monitoring and simulation** - Enhanced crop monitoring formed the basis of project work, with soil sample information used to initialise the model for subsequent simulation runs. Post harvest samples were also taken to assess the nitrogen uptake by the cotton crop and future management options. This monitoring improved the accuracy of the modelling but also provided key information to explain the crops response to management and weather conditions. Growers and consultants found this information very important when reflecting on the crops performance following harvest. Subsequent long term simulations focussed, in the main, on crop performance under reduced water allocation scenarios and changed irrigation parameters.
2. **Farming systems analysis** - The OZCOT and APSIM models were used to interpret and extrapolate results collected from the CRC farming system trials. Collation of data from the Warra Farming System trial took 3 years to complete, and model validation carried out. Reasonable yield accuracy has been achieved, although some rotations, notably wheat following cotton, have not been simulated well. The OZCOT model was also used to address questions about earliness management strategies, irrigation frequency and ultra-narrow row cotton.
3. **Delivery mechanisms of simulation** - Development of a user-friendly version of OZCOT was achieved during the course of the project. A training workshop was held to instruct the Industry Development Officers and researchers in using Ozcot and some potential applications. The APSIM Training, Accreditation and Licensing Program, which aims to investigate and evaluate the use of the FARMSCAPE with agribusiness, was established in 2000. Four companies were selected and are now participating in the training and accreditation program. Representing the Cotton CRC, Dirk Richards has been undergoing accreditation under the scheme, to provide access to APSIM to the cotton industry in the long term and implement the FARMSCAPE approach in Ozcot support and training. Consultancy simulation services to commercial companies and government departments were provided on demand.

## Warra Crop yields Actual vs Simulated

Season		1 Continous Cotton	2 Cotton/ Summer Cereal	3 Cotton d/c Winter cereal	4 Cotton/ Winter Legume	5 Cotton/ Winter cereal
Summer 1992/93	Actual Simulated	Cotton	Cotton	Cotton	Cotton	Cotton
Winter 1993	Actual Simulated			Barley 0.22 t/ha	Barley 0.22 t/ha	
Summer 1993/94	Actual Simulated		Sorghum 2.1 t/ha			
Winter 1994	Actual Simulated				Chickpea 0.66 t/ha	Wheat 1.43 t/ha
Start of simulations, Day 266 1994						
Summer 1994/95	Actual Simulated	Cotton 3.73 b/ha 4.36 b/ha	Cotton 3.05 b/ha 4.1 b/ha	Cotton 4.05 b/ha 4.19 b/ha		
Winter 1995	Actual Simulated			Durum Wheat 0.42 t/ha 0.55 t/ha		
Summer 1995/96	Actual Simulated		Sorghum 5.77 t/ha 7.69 t/ha		Cotton 4.45 b/ha 4.37 b/ha	Cotton 4.5 b/ha 4.38 b/ha
Winter 1996	Actual Simulated				Wheat 2.7 t/ha 1.14 t/ha	Wheat 2.7 t/ha 1.14 t/ha
Summer 1996/97	Actual Simulated	Cotton 3.35 b/ha 3.79 b/ha	Cotton 3.21 b/ha 4.11 b/ha	Cotton 3.8 b/ha 4.13 b/ha		
Winter 1997	Actual Simulated			Wheat 3.05 t/ha 1.82 t/ha	Chickpea 2.57 t/ha 2.38 t/ha	
Summer 1997/98	Actual Simulated		Sorghum 3.05 t/ha 3.09 t/ha			Cotton 2.7 b/ha 2.8 b/ha
Winter 1998	Actual Simulated					Wheat 4.04 t/ha 4.64 t/ha
Summer 1998/99	Actual Simulated	Cotton 3.47 b/ha 2.73 b/ha	Cotton 3.25 b/ha 2.73 b/ha	Cotton 3.04 b/ha 2.73 b/ha	Cotton 4.41 b/ha 2.73 b/ha	

## Cropping Systems Models in the Australian Cotton Industry

M.P. Bange<sup>1</sup>, P.S. Carberry<sup>2</sup>, and D. Richards<sup>1</sup>

<sup>1</sup>CRC for Sustainable Cotton Production, CSIRO Plant Industry Cotton Research Unit

<sup>2</sup>Agricultural Production Systems Research Unit, CSIRO Tropical Agriculture

### Introduction

Managing any cropping system involves making decisions and with that comes the risk of making a wrong decision especially when many of the factors involved are unknown or uncertain (eg. rainfall). Collaborative projects undertaken by the CSIRO Cotton Research Unit (CRU) and the Agricultural Production Systems Research Unit (APSRU) have been using crop simulation models to assess the impact of decisions on crop and system performance without suffering the consequent pain and real life experience when mistakes are made. Two crop simulation models are being used in this research. One model is the cotton simulation model OZCOT developed by Dr Brian Hearn at CRU which provides a useful and very powerful tool for obtaining a long term historical perspective for specific problems in cotton production. The second model developed by APSRU is called APSIM (Agricultural Production Systems Simulator) and it has the capability to simulate many aspects of the cropping system, including a range of crops grown in rotation or with fallows. The cotton module in APSIM is the OZCOT model developed by CSIRO Cotton Research Unit at Narrabri.

### Research Methodology

Recent efforts in applying cropping simulation models to commercial farm management are utilising participatory research approaches. FARMSCAPE (*Farmers, Advisers, Researchers, Monitoring, Simulation, Communication And Performance Evaluation*) (McCown et al., 1998) is an acronym employed to represent the participatory action research approach that explicitly addresses the question of the relevance of systems models to commercial farming. This approach has provided an excellent means for allowing farmers and advisers to become actively involved in the implementation of the research and interpretation of the outcomes. It has also provided the mechanism for all participants (including researchers) to learn more about their respective farming systems.

### Crop Simulation in Commercial Farm Management

#### *Benchmarking the performance of models and crops*

Benchmarking the performance of models against measured crop yields and visa versa has been an important component of this research and was undertaken for two reasons. Firstly to establish model credibility and relevance to commercial farming systems, and secondly to assess the performance of crops at the end of the season with predicted potential yield. Generally the model has simulated crop yields well (Fig.1) and has

information, the models can provide an assessment of expected crop performance in the upcoming season by simulating what would have happened under these same conditions in past years for which climate records exist. Some examples for cotton production are the choice of planting a crop as either solid or single skip row configuration under low starting soil water conditions, or even considering sorghum crop as an alternative option.

## **The Future**

Developing the FARMSCAPE approach and tools to the point of commercial delivery is presently the main focus of research using cropping systems models (CRDC project CSP98C Delivering to industry the benefits of cropping systems models). A market now exists for timely and high quality interactions based on soil monitoring and simulation amongst a significant sector of the dryland farming community. One preferred delivery mechanism is to establish and support an Accredited Adviser Network of agribusiness and private consultants for delivering simulation and related products. Research is also focused on expanding efforts to include irrigated cotton production systems and include other agribusiness service sectors (bank lenders, crop insurance, product inventory, marketing advice, etc.). Other activities that involve cropping systems models that are planned, about to commence or are presently being undertaken involve:

- Using models to assess the impact of water use efficiencies in the farming system.
- Developing a more user friendly cotton model.
- Investigating the impact of climate variability and forecasting.
- Simulating the farming system trials.
- Incorporating the effects of compensation into the cotton simulation model.
- Using cropping system models to assist in area wide management.
- Linking cropping systems models to site specific farming projects.

## **References**

- Carberry, P.S. and Bange, M.P. 1998. Using systems models in farm management. In Proc. 9<sup>th</sup> Aust. Cotton Conf. 10-14 August, Gold Coast Aust. The Aust. Cotton Growers Research Organisation, pp. 153-160.
- McCown, R.L., Carberry, P.S., Foale, M.A., Hochman, Z., Coutts, J.A. and Dalgliesh, N.P. 1998. The FARMSCAPE approach to farming systems research. P. 633-636. Proc. 9<sup>th</sup> Aust. Agron. Conf. Charles Sturt University, Wagga Wagga.
- McCown, R.L., Hammer, G.L., Hargreaves, J.N.G., Holzworth, D.P. and Freebairn, D.M., 1996. APSIM: A novel software system for model development, model testing, and simulation in agricultural research. *Agric. Syst.* 50: 255-271.

## **Acknowledgements**

The contribution from colleagues in APSRU, CSIRO CRU, QDPI, IAMA Ltd., Michael Castor and Associates and many farmer and advisers is gratefully appreciated. Thanks to the Australian Cotton and Grains R & D Corporations and the CRC for Sustainable Cotton Production for their support.

## **Delivering to industry the benefits of cropping systems models**

D. Richards<sup>1</sup>, M.P. Bange<sup>1</sup>, and P.S. Carberry<sup>2</sup>

<sup>1</sup>CRC for Sustainable Cotton Production, CSIRO Plant Industry Cotton Research Unit

<sup>2</sup>Agricultural Production Systems Research Unit, CSIRO Tropical Agriculture

### **Background**

All cotton growers, dryland and irrigated, are basically risk managers. Crop management decisions such as sowing date, nitrogen application and irrigation scheduling involve some degree of uncertainty in the effect on crop growth, in addition to the variability of rainfall and climate. Simulation models can help analyse the performance of crops under different environmental and management conditions. They are a means of easily and efficiently achieving understanding and gaining "experience", without suffering the delay and consequent cost of real-life experience when mistakes are made. Coupled with nitrogen and soil moisture information from deep soil sampling, growers can make informed management decisions with less risk.

This collaborative project is being undertaken by the CSIRO Cotton Research Unit (CRU) and the Agricultural Production Systems Research Unit (APSRU). It builds on the success of a previous CRDC funded project, which worked closely with dryland growers and their consultants in establishing how simulation models and soil monitoring could assist them towards better farm management. The aims are to expand the participatory research to include irrigated farms, providing growers and consultants with information on their soil, benchmark the performance of commercial crops and the impact of their management decisions within the context of the whole climate record rather than a single season. Other points of significance include simulation of the rotations being trialed in the CRC Farming Systems trials and research on the prospects for commercial delivery of systems simulation to industry clients.

Two crop simulation models are being used in this research, primarily OZCOT and the Agricultural Production Systems Simulator (APSIM). The OZCOT cotton model is capable of mimicking the response of cotton to many climatic and agronomic factors, and provides a useful and powerful tool for obtaining a long term historical perspective for specific issues in cotton production. OZCOT was developed by Dr Brian Hearn at CRU and is a component in APSIM. The APSIM model was developed by APSRU and has the capability to simulate many aspects of the cropping system, including a range of crops grown in rotation or with fallows.

### **Progress**

Several new participatory research groups have been formed with irrigated growers in northern New South Wales and on the Darling Downs in Queensland. Initial simulations have involved finetuning the models for irrigated production, and are now being used to explore issues such as limited water situations, irrigation frequency and timing, and

conjunction with Mark Hickman (NSW Agriculture) and DeltaPine. Initial validation simulations have given the desired final yields (Figure 2), but the early square and fruit development curves fail to reflect the earliness found in the UNR system. Incorporating fruit count information collected during the season may correct this.

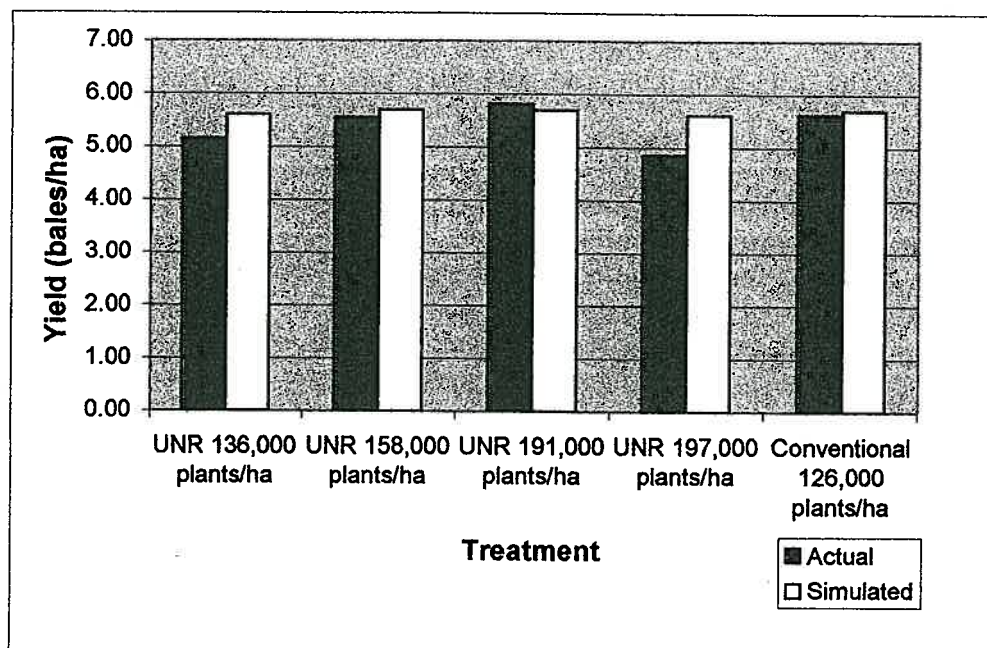
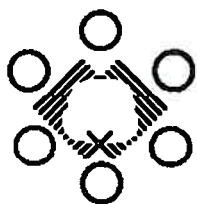

Figure 2. Initial OZCOT modelling results benchmarked against the UNR trial at Breeza, 1998/99 season.

Simulation of the CRC Farming Systems trials has involved development of input files and collation of soil parameter information. This work is ongoing and it is hoped that modelling results can assist in assessment of treatments and seasonal variability.

A market now exists for this simulation technology amongst a significant sector of the farming community. To satisfy this demand a GRDC FARMSCAPE Accreditation project has been established to allow four licensed agribusiness companies and up to 10 advisers to use APSIM (+OZCOT) in their agronomic advisory services. This project begins in July 1999 and will allow growers to make better use of seasonal climate forecasts and conduct "what-ifs analysis" specifically for their farms in the northern cropping region.



## Agronomic research to support the development of crop simulation models

*Stephen Milroy and Michael Bange*  
CSIRO Cotton Research Unit, Locked Bag 59, Narrabri 2390

### Background

The CRC facilitates links to a number of areas of agronomic and crop physiology research as well as important links to people involved in applying models in various ways.

The involvement of research staff in the application of the model for on farm decision support provides a useful link back to those involved in model development. It allows rapid feedback on the robustness of the model under varying environmental and management conditions as well indicating priorities for developing new functionality required for decision support. In turn this helps indicate research priorities in terms of crop growth and response to climate.

Current research activities cover a number of areas of cotton agronomy and crop physiology. Some of these are outlined below.

### Water Extraction by Skip Row Cotton Crops

The increasing importance of dry land cotton production has resulted in a need to be able to reliably simulate cotton growth, development and yield when produced on different row configurations under limited water supply. To do this, one of the important processes the model must simulate is water extraction from different parts of the interrow space. Two successful projects have recently been completed by Dr Phil Goyne of DPIQ, Warwick, in which water extraction from five points within the planting row and the skip were monitored for solid planted cotton, single skip and double skip. The experiments encompassed a number of soil types and wide year to year variation in rainfall patterns. Some of his data is presented in his paper in these proceedings. This information will be used to improve the operation of the soil water balance in the simulation model for different row configurations.

peak square number than L22 at any sowing time. The research is widening to include a range of currently available cultivars.

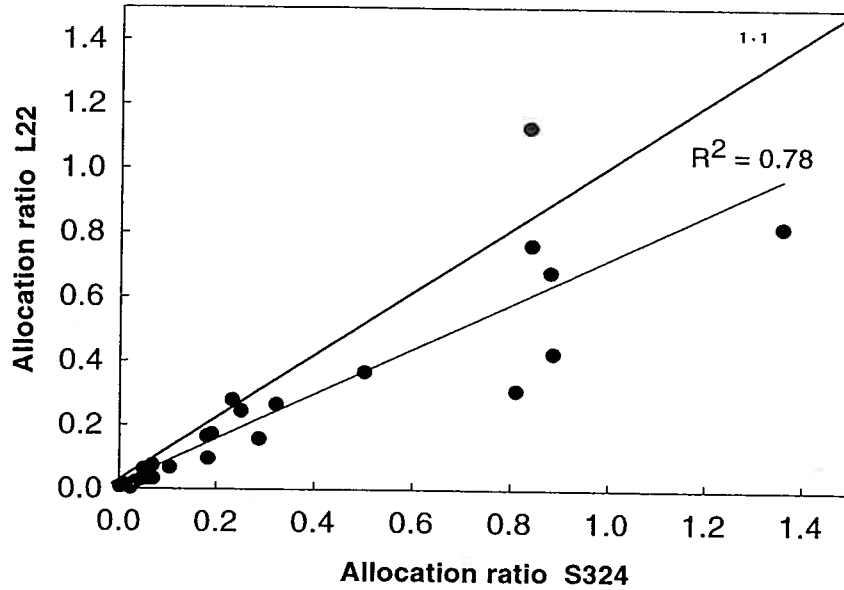

**Figure 1:** Comparison of the allocation ratio (proportion of new biomass going to fruit) of Siokra L22 compared to that of S324 in the first field experiment. S324 always partitioned proportional more biomass to the fruit.

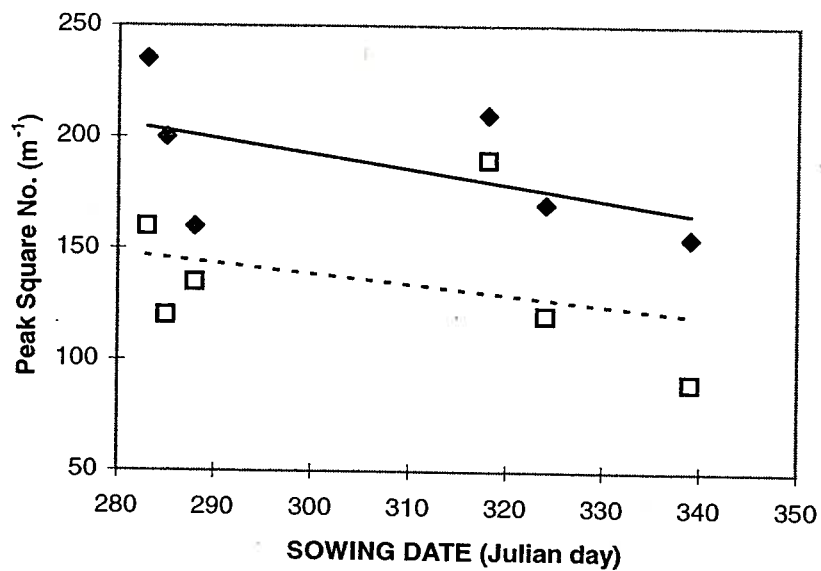

**Figure 2:** At all times of sowing Siokra S324 always had a higher peak square number than Siokra L22. Closed symbol and solid line = S324, open symbols and broken line = L22.

As described in his paper Marc Ellis (Australian Cotton CRC, CSIRO Plant Industry) has developed a number of transgenic lines which have been genetically modified to increase the activity of two key enzymes in the alcoholic fermentation pathway (*Pdc* and *Adh*). The aim is to allow metabolism to continue under low oxygen conditions. These lines are being tested in the field at Narrabri. To determine whether there is any benefit in the modifications, the growth and yield of the lines under waterlogged conditions is being compared to that under non-waterlogged conditions. Characters being assessed include leaf chlorophyll content, photosynthetic rate, fruit production and fruit retention.

The plant hormone AVG is also being trialed. This compound blocks the production of ethylene which is an important mediator in the senescence of organs, either naturally or in response to a stress such as waterlogging. However, this chemical may have negative impacts in terms of modifying rooting patterns and possibly delaying the maturation of the fruit. Its effects will need to be fully explored.

#### **Future directions**

Much of this work is still in progress. The first priority is the completion of the analysis for varieties of different maturity times and incorporating the results into the model. The work is being widened to include the collection of parameters for cultivars of different maturity lengths which cover a more diverse range of genetic backgrounds and to collect parameters for current cultivars.

The field research into waterlogging is just commencing. The new *Pdc* lines being generated by Marc Ellis and the new crosses of *Adh* and *Pdc* transformed lines will be included in the field program.

As well as increasing our understanding of how cotton responds to environmental factors and helping develop new ideas for cotton management, this research will be incorporated into the simulation model to enhance its ability to deal effectively with range of conditions. This will increase its usefulness and robustness in both research and decision support applications.

## Appendix 5.

## EARLY SEASON INSECT DAMAGE IN DOUBLE SKIP COTTON CROPS

By Dirk Richards<sup>1</sup>, Michael Bange<sup>1</sup> and Lewis Wilson<sup>1</sup>

CSIRO Cotton Research Unit, Narrabri, NSW<sup>1</sup>  
Australian Cotton Cooperative Research Centre,

### **Abstract**

We tested the suggestion that early season damage may limit the crops subsequent exploitation of moisture in the skip row, which may in turn limit the crops ability to recover. Over two seasons the recovery response of dryland double skip cotton was investigated, where artificial damage was used to simulate damage caused by thrips or *Helicoverpa*. Treatments included defoliation and/or tip damage. None of the treatments significantly affected yield, however there was a consistent trend towards lower yield in heavier damage treatments. Moisture extraction from the plant row and skip did not appear to be correlated with plant damage, although seasonal weather conditions may have affected this result. Earliness was not specifically assessed but heavy damage treatments appeared slightly delayed. These experiments suggest that factors other than early season damage may be affecting the plants ability to extract moisture from the skip row. Further work in this area needs to be conducted to assess the impact of damage on skip row cotton and factors affecting extraction.

### **Introduction**

The effect of early season defoliation and tipping out in irrigated crops has been well documented, and although these results may have some relevance to double skip dryland crops, trial work in this area has been somewhat limited. Amongst growers and consultants there are several theories about the likely impact. One theory is that early plant damage restricts the plant at a crucial development stage, which then limits root growth and the capacity of the crop to extract moisture later in the season, and subsequently delay crop maturity. Following discussions with James Clark, a dryland cotton grower at Croppa Creek, and Michael Castor, Michael Castor and Associates, a trial was established at Croppa Creek during the 1998/99 cotton season to investigate in-field responses of cotton to simulated early season pest damage and subsequent impacts on moisture extraction.

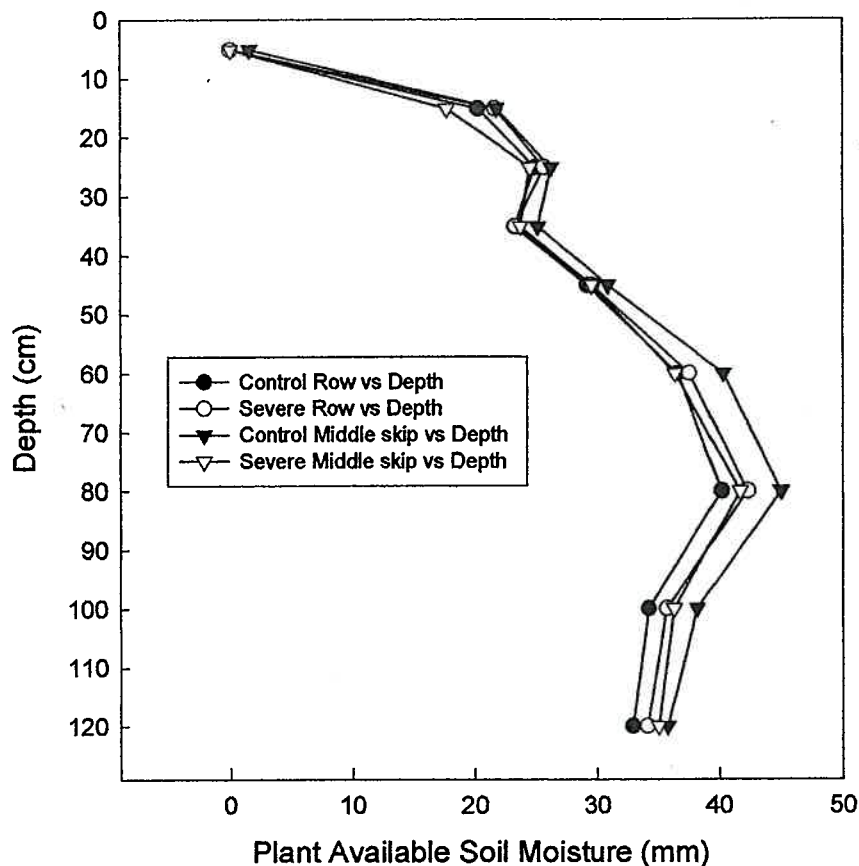

**Figure 1.** Plant available soil moisture on 20 November 1998

Yield results are presented in Figure 2 and show a substantial yield penalty under the severe damage treatment (80% defoliation and tipping out at 3,6 and 8 leaves). The heavy damage did cause delayed maturity, with a significant number of unopened green bolls at harvest. However, the light damage treatments probably represent more realistically the degree of early season damage caused by thrips and *Helicoverpa*, and these were not significantly different from the controls. There was a trend to lower yield in the heavy defoliation treatment (80% of leaves removed at 3 and 6 true leaves). Gin turnouts and fibre quality were unaffected by any of the damage treatments.

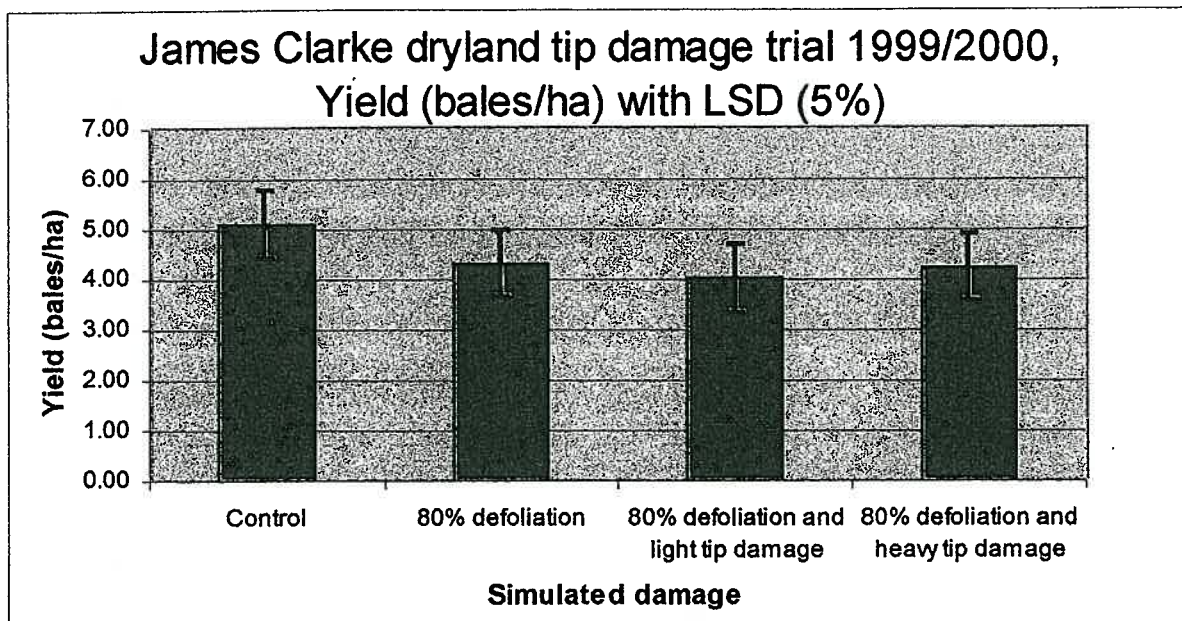

**Figure 3.** 1999/2000 yield results (note: handpick yields).

Comparisons of boll number during maturity picks revealed no statistically significant differences, however the control treatment had consistently higher numbers of mature bolls, and from this some degree of earliness could be expected. An assessment of gin turnout and boll weight again revealed no significant differences between treatments.

## Conclusion

Soil moisture extraction under dryland conditions is highly variable and exploitation of the skip row can be affected by many factors. Investigation of the impact of plant damage on this extraction capacity suggests that damage by thrips and *Helicoverpa* during early season plant growth may not limit the plant ability to exploit soil moisture at depth and in skip. Rather, that weather conditions experienced during crop growth will have a greater impact on the range of soil moisture extraction. There is some scope to use seasonal forecasts to allow planting to a solid configuration during seasons which have been forecast to receive above average rainfall, during which the crop will not be limited by soil moisture.

The cool conditions in both years may have reduced the rate of compensation before the season came to a finish, but do show that double skip cotton could tolerate increasing levels of

## Crop Models and Decision Support – Future Developments and Applications

Michael Bange<sup>1</sup>, Sandra Deutscher<sup>1</sup>, Chris Plummer<sup>1</sup>, David Larsen<sup>2</sup>, Darren Linsley<sup>1</sup>, Dirk Richards<sup>1</sup>, Stewart Whiteside<sup>1</sup>

CSIRO Plant Industry, Cotton Research Unit, Narrabri, NSW<sup>1</sup>

NSW Agriculture, Narrabri, NSW<sup>2</sup>

Australian Cotton Cooperative Research Centre

### Introduction

Managing sustainable cotton production is becoming more difficult with the ever-increasing demand on limited resources. In addition cotton growers are facing increased pressures to manage resources more cost effectively and to be more accountable for the impact that their decisions make on the surrounding environment. Computer based decision support systems and simulation models are being developed to provide cotton growers with the best information and tools available from research to assist with their management decisions. A primary aim of the decision support and modelling teams in the cotton industry is to utilise sound and up to date technology, and integrate this technology across different electronic platforms and mechanisms, and finally delivering it to the industry for adoption 'Science into Practice' (Fig.1).

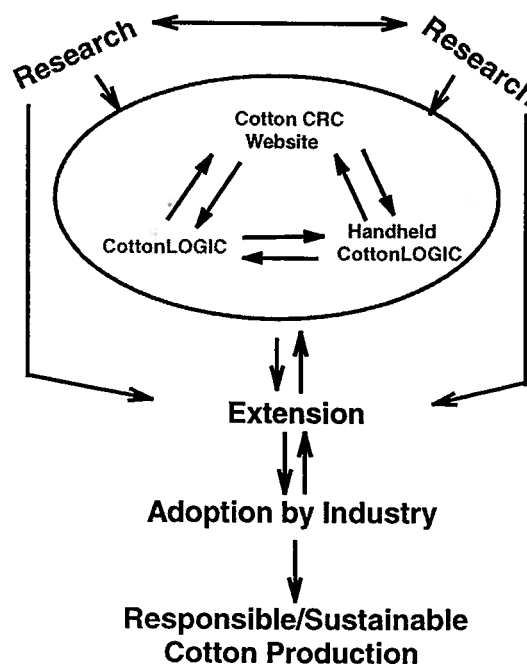

Figure 1. Putting 'Science into Practice' through computerised decision support.

7. Make activities and decisions transparent to superiors, industry and funding bodies.
8. Produce quality outcomes, thoroughly tried and tested.
9. Decision support systems are just that, they do not make the decisions, but provide information to assist in the decision-making processes. Promote the decision support systems as tools. (e.g. Promote IPM, and CottonLOGIC helps achieve this)

Successful development and delivery of decision support for adoption by industry encompasses many different processes from the conception of an idea through to delivery and support. Some of the important functions and activities of the decision support team are outlined in Table 1.

**Table 1:** Team functions and examples of activities of the decision support team.

Team Function	Example of activities
Software development	Software engineering, coding, and testing
Education and training	CottonLOGIC workshops, field days
Support	Phone support at the Cotton CRC's Technology Resource Centre (TRC)
Industry Feedback	Workshops, TRC, Industry Steering Committee
Packaging and Distribution	CottonLOGIC packages, and mailouts through the TRC
Promotion	Attendance at trade shows, local shows with the TRC
Scientific Review	Attendance at Scientific Conferences, Peer Review
Field Validation	Regional specific field trials using CottonLOGIC, working with the Industry Development Officers
Project Evaluation	Surveys, Independent feedback from Consultant
Administration	Personnel management, sourcing funding

## Significance of Decision Support and Modelling to Industry

### CottonLOGIC

The development of any computerised decision support package relies on constructive feedback from its stakeholders. Based on different forms of feedback and assessment it has shown that CottonLOGIC is highly valued and accepted in the industry as a tool to assist with crop management.

Apart from the day to day informal feedback that the decision support team obtains, the group also uses other mechanisms to ascertain importance and industry needs for decision support development. In the past year the group has conducted one phone survey, one workshop survey as well as employing the services of an independent consultant specialising in decision support. While the information gathered has highlighted deficiencies, it has also, demonstrated overwhelming support for computerised decision

Survey participants were also given the opportunity to make any comments relating to further development of the package. A detailed list of issues highlighted by the relevant groups was presented in Australian CottonGrower Magazine (Bange et al., 1999).

In the past year emphasis was also placed on assessing the training given by the decision support group. Significant effort has occurred in redesigning and improving the workshops to cater for the greater numbers attending, and to suit a range of learning styles of the participants. Evaluation was conducted by allowing the participants at last year's workshops to answer some simple questions relating to the delivery and importance of the workshops. Of the total of 250 participants that attended the workshops, 100% of the responses thought that the workshop was useful while 98.7% said that they would attend the workshops in the future. In addition 80% of responses said that they would not like to see any changes in the present workshop format.

Most importantly the past year the decision support group has employed the services of an independent consultant systems Mr Peter Van Beek specialising in assessing the importance and impact of decision support. Mr Van Beek has conducted numerous (30+) interviews with a range of different stakeholders in the industry. A comprehensive report of the major findings was completed and presented to the group. The report was extremely positive, highlighting the importance of CottonLOGIC and decision support to the industry both directly and indirectly. The assessment also played a significant role in identifying the problems and deficiencies in decision support development and provides a basis on which to improve. Some quotes taken from the report are below:

'The science behind CottonLOGIC was seen as one of its valuable aspects'.

'The use of CottonLOGIC had effected relationships with consultants and other stakeholders'.

'One saw CottonLOGIC as a back-up and verification, and would be upset if it was not regularly updated'.

'Consultants would survive without CottonLOGIC, but not having it would be a disaster for the industry, as it is important in disseminating information'

'The new versions come out too late to try changes, familiarise, and train staff in the applications'.

A decision support team workshop has been held to discuss the findings and structure a work-plan to address some of the issues. The results of the workshop will be presented to the industry's decision support steering committee for further discussion.

### **Crop Simulation Models**

Research on the application of crop simulation models such as OZCOT involves both the Agricultural Production Systems Research Unit (APSRU) based in Toowoomba working closely together with researchers from Narrabri. The focus of the research is now on identifying the appropriate means of delivering this technology to industry as well as addressing and identifying appropriate needs for irrigated cotton growers. This has come about after a highly successful project that used this technology with

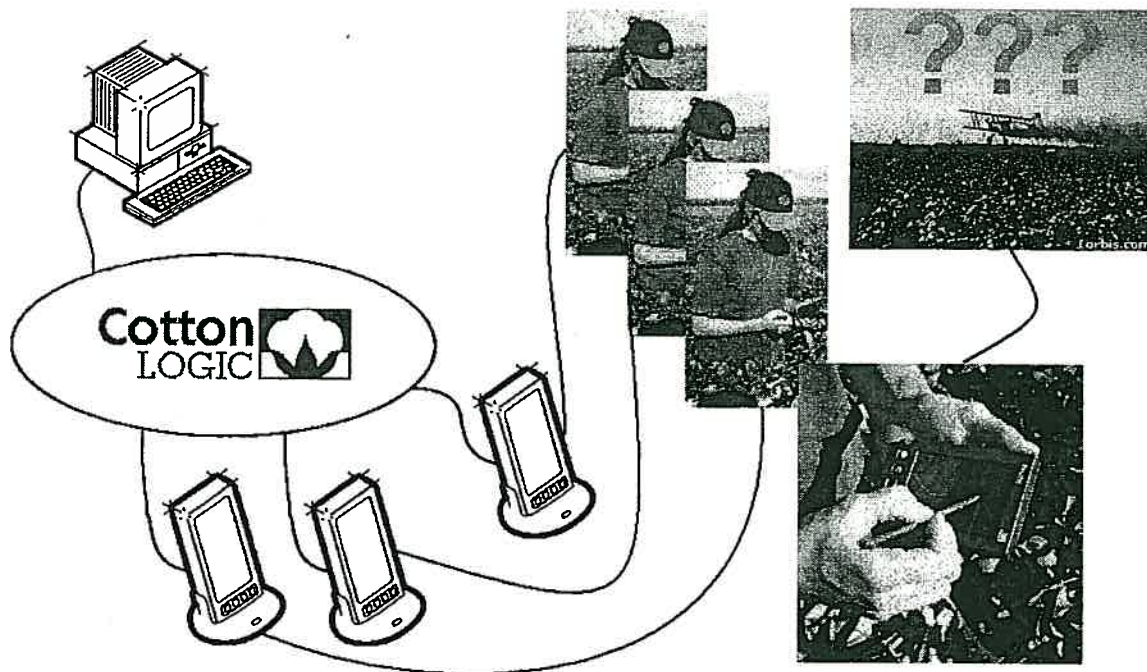

**Figure 3:** The Palm Pilot handheld device and a diagram describing the operation of use of the device with a desktop version of CottonLOGIC.

### **Development utilising the World Wide Web and OZCOT**

Another platform for delivery of information and decision support that is showing ever-increasing support is the Internet (WWW). Substantial improvements in the web infrastructure, management, and appearance of the Cotton CRC web site have occurred. The Technology Resource Centre now operates a fully functional and interactive web site that provides information such as: current weather data from the cotton industries met stations; cotton industry publications; diary of events within the cotton industry; industry contacts; and providing the latest research information available within the industry.

Significant improvements in the last year have been implemented, they are: personal details can now be passed securely; development of a cotton degree-day calculator accessed through the Cotton CRC website that accesses the Bureau of Meteorology's climate database and the Queensland Department of Natural Resources Patched Point Data Set (PPD) (through the SILO project); and greater links with the CottonLOGIC software have been established.

Greater links and developments with the SILO project are progressing some examples include:

- Access to more accurate accumulated day degree value accessed via the Internet through CottonLOGIC for use with NutriLOGIC and other simulation models.

## **Conclusion**

The development of computerised decision support is an ongoing process that is constantly responding to changing industry, biological, environmental and technical issues. The decision support and modelling teams will endeavour to respond to these changes and meet the needs of industry and wider community by assisting the cotton industry to become sustainable and environmentally responsible. For information and free copies of CottonLOGIC contact David Larsen, the coordinator the Australian Cotton CRC's Technology Resource Centre on (02) 679915534.

## **References**

Bange, M., Deutscher, S., and Plummer, C. (1999). CottonLOGIC: Survey shows the way forward. 20(4). The Australian Cottongrower. pp.40-42.

## **Acknowledgments**

Components of this research and development is funded by the Cotton Research and Development Corporation, The Australian Cotton Cooperative Research Centre and the Grains Research and Development Corporation.

**Assessing the risk of cotton 'earliness' management strategies with crop simulation.**

D.Q. Richards, M.P. Bange and G.N. Roberts

Australian Cotton Co-Operative Research Centre

Cotton Research Unit, Division of Plant Industry, Commonwealth Scientific and Industrial Research Organisation, P.O. Box 59, Narrabri, New South Wales, Australia, 2390

**ABSTRACT**

Earlier crop maturity (earliness) in the Australian cotton crop is an attribute many growers seek to attain, with the primary aim to avoid climatic influences on yield and quality, and late season insecticide applications, allowing a reduction in costs and helping to avoid insecticide resistance. Crop simulation models offer the ability to assess many crop management options that affect earliness over many locations. This paper compares the results of field measurements of crop yield and maturity, with information generated by the model. The OZCOT model simulated yield accurately but maturity was not modelled accurately, indicating an area for future work. Long-term climate information is also used to identify "windows of opportunity" for growers to manage crops for earliness and avoid crop losses due to climatic influences.

**KEY WORDS:** earliness, models, climate, risk, irrigation, nitrogen

**INTRODUCTION**

'Earliness' is a term peculiar to the cotton industry, and embodies the desire to harvest the crop as soon as possible without incurring a significant yield penalty. Delayed crops increase chemical costs and risk exposure to greater degrees of climatic risk, which may affect parameters such as fibre quality. Factors affecting earliness include sowing date, insect control, soil nitrate level at sowing and the timing of last irrigation. Simulation models offer an opportunity to simulate crops over a wide range of environmental and management conditions, and are a means of easily achieving understanding of a system and not suffering the consequent pain and cost of real-life experiments (2). Australian cotton is grown in one of the world's most variable climates, particularly rainfall, however an analysis of the rainfall distribution during March, April and May will provide some insight into ideal dates for cotton harvest.

**METHODS**

A simulation model is simply a mathematical representation of the physiology of a crop. The OZCOT computer simulation model uses historical weather data, basic soil parameters and defined crop management options to give estimates of potential crop yields. The OZCOT model has been developed over the past 30 years, and incorporates research into the response of cotton to climatic variables (5). When used in conjunction with accurate measurements of soil water and nitrogen just prior to sowing, OZCOT has been shown to successfully compare alternative agronomic management options. A validation sequence of model runs was conducted using information collected during 1999/2000 (7), covering two different climatic regions. Further details about these earliness trials can be found in Roberts and Constable (7) contained in these proceedings. These simulations used the attributes listed in Table 1 to initialise the model and were used to assess the application of the OZCOT model in quantifying earliness strategies.

The strategic simulations assessed two factors known to affect earliness, soil nitrate level (kg/ha) at sowing and the timing of last irrigation, using the long season variety grown at Goondiwindi and Boggabri. Figure 2 shows the results using soil nitrogen increments of 50kg/ha, indicating an optimum yield is achieved at 200kg/ha, which is consistent with the results of Rochester et al (3). As the validation simulations indicated the model did not predict maturity accurately, the maturity information for the strategic simulations was not used. Research findings from the United States presented by McConnell et al (6) show that increasing the nitrogen rate reduces earliness. This is consistent with findings under Australian conditions at Narrabri, NSW, where every 50kg of nitrogen delayed maturity by 2 days, and significant delays were experienced above the optimum nitrogen rate of 200kg (I. Rochester, CSIRO, unpublished data).

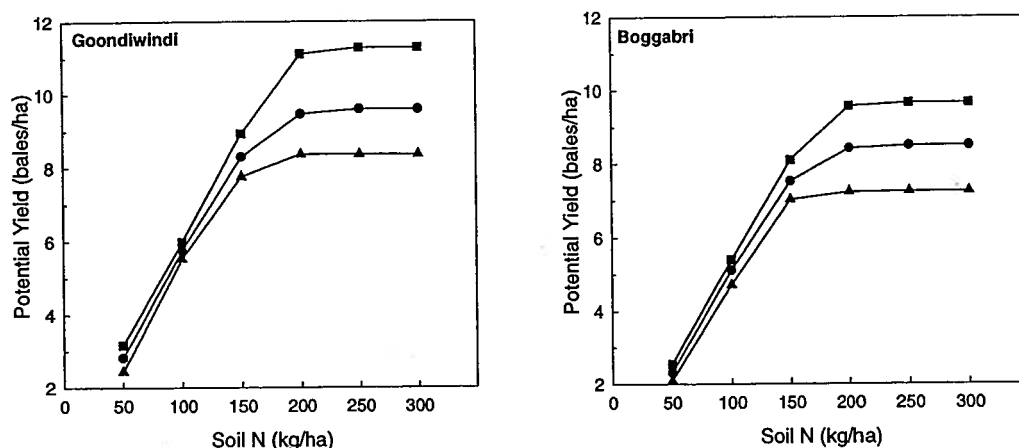

**Figure 2.** Soil nitrogen at sowing simulation results for Goondiwindi and Boggabri showing potential yield: Points shown are average (●), 20<sup>th</sup> percentile (▲) and 80<sup>th</sup> percentile (■).

The timing of last irrigation simulations are presented in Figure 3 and show a different response at the two locations, possibly due to climate. Very little change in yield could be achieved at Boggabri by varying the date of last irrigation from 1% to 60% open bolls, possibly indicating that other parameters, such as temperature, are impacting on crop yield. An analysis of Goondiwindi results shows a potential to increase yield with later irrigations, but this may have negative implications for maturity. This yield increase is consistent with results presented by Hearn (4), and Hearn and Constable (5), where yield was shown to increase with later irrigations but the duration of protection from insects was prolonged and harvest delayed due later maturity.

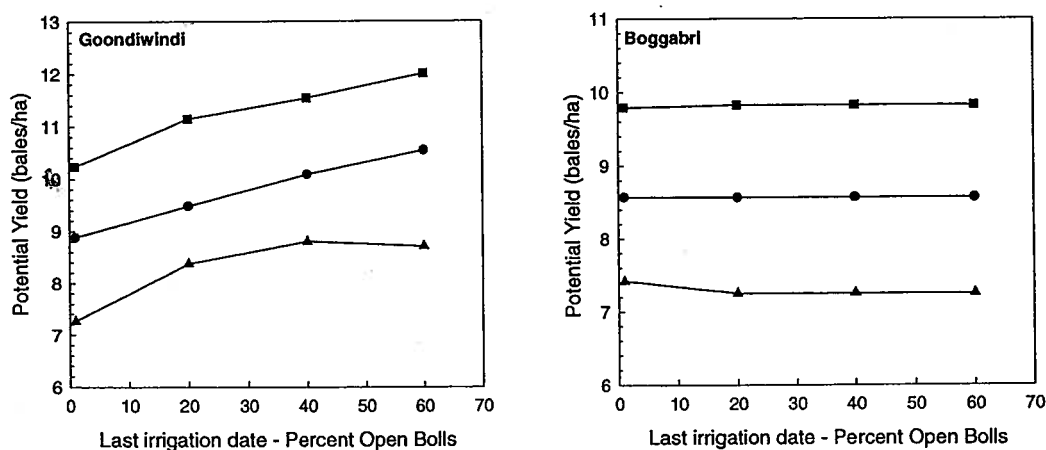

**Figure 3.** Last irrigation simulation results for Goondiwindi and Boggabri showing potential yield: Points shown are average (●), 20<sup>th</sup> percentile (▲) and 80<sup>th</sup> percentile (■).

### Decision Tools for Crop Rotation and Management Systems

Michael Bange, CRC for Sustainable Cotton Production (CSIRO Plant Industry Cotton Research Unit), Locked Bag 59, Narrabri, NSW 2390. Ph. (02) 67991540, Fax. (02) 67991582, Michael.bange@pi.csiro.au.

Peter Carberry, Agricultural Production Systems Research Unit P.O. Box 102, Toowoomba, QLD 4350. Ph. (07) 46881377, Peter.carberry@tag.csiro.au.



Many agronomic decisions involve risk as many of the factors involved are unknown or uncertain (eg. rainfall). History can often serve as our best guide to the potential risks and benefits of a particular strategy. The use of crop simulation models is a powerful, and often the only, way to address such issues without suffering the consequent pain and real life experience when mistakes are made. A Participatory research approach (FARMSCAPE - *Farmers, Advisers, Researchers, Monitoring, Simulation, Communication And Performance Evaluation*) was used to address key issues in dryland crop management through on-farm trials, crop and soil monitoring, and simulation modelling (using OZCOT and APSIM). This approach has provided an excellent means for allowing farmers and advisers to become actively involved in the implementation of research and interpretation of the outcomes. It has also provided the mechanism for all participants (including researchers) to learn more about their respective farming systems.

Farmers benefit from understanding their soils and knowing the current status of their soil nitrogen and water availability. This information, while initially collected to use simulation models has become in itself a valuable source of information for farmers. The development of robust and inexpensive equipment now allows for simple characterisation of the soil with respect to plant rooting depth and plant available soil water holding capacity; and to allow rapid measurement of soil water and nitrogen status at depth. Farmers are using this information to change management practices such as fertiliser rates or crop selection, or to confirm their existing strategies.

Monitoring crops is also an important part of establishing the credibility of the models and their relevance to commercial farming practices. For many farmers and consultants, APSIM and OZCOT have proved credible enough to be relevant to commercial cropping practices (Figure 1) and they now use them for benchmarking the performance of their own crops and in exploring alternative management strategies. Some common uses of the tools developed in this research have been to:

- Provide information to extension and agribusiness for assessing the potential of other crops in present farming systems.
- conduct risk analyses for production in new areas (eg. cotton in northern Australia).
- Simulate farming systems so as to examine sustainability and environmental issues such as soil fertility, economic returns and risks, organic carbon, and erosion.
- Assist in decision making for the current or upcoming crop. Decisions on crop choice, varietal selection, fertiliser rate, sowing date, plant population, row configuration and so on

# Seasonal climate forecasting for cotton management

Appendix 9.

By Michael Bange<sup>1</sup>, Peter Garberry<sup>2</sup> and Graeme Hammer<sup>2</sup>

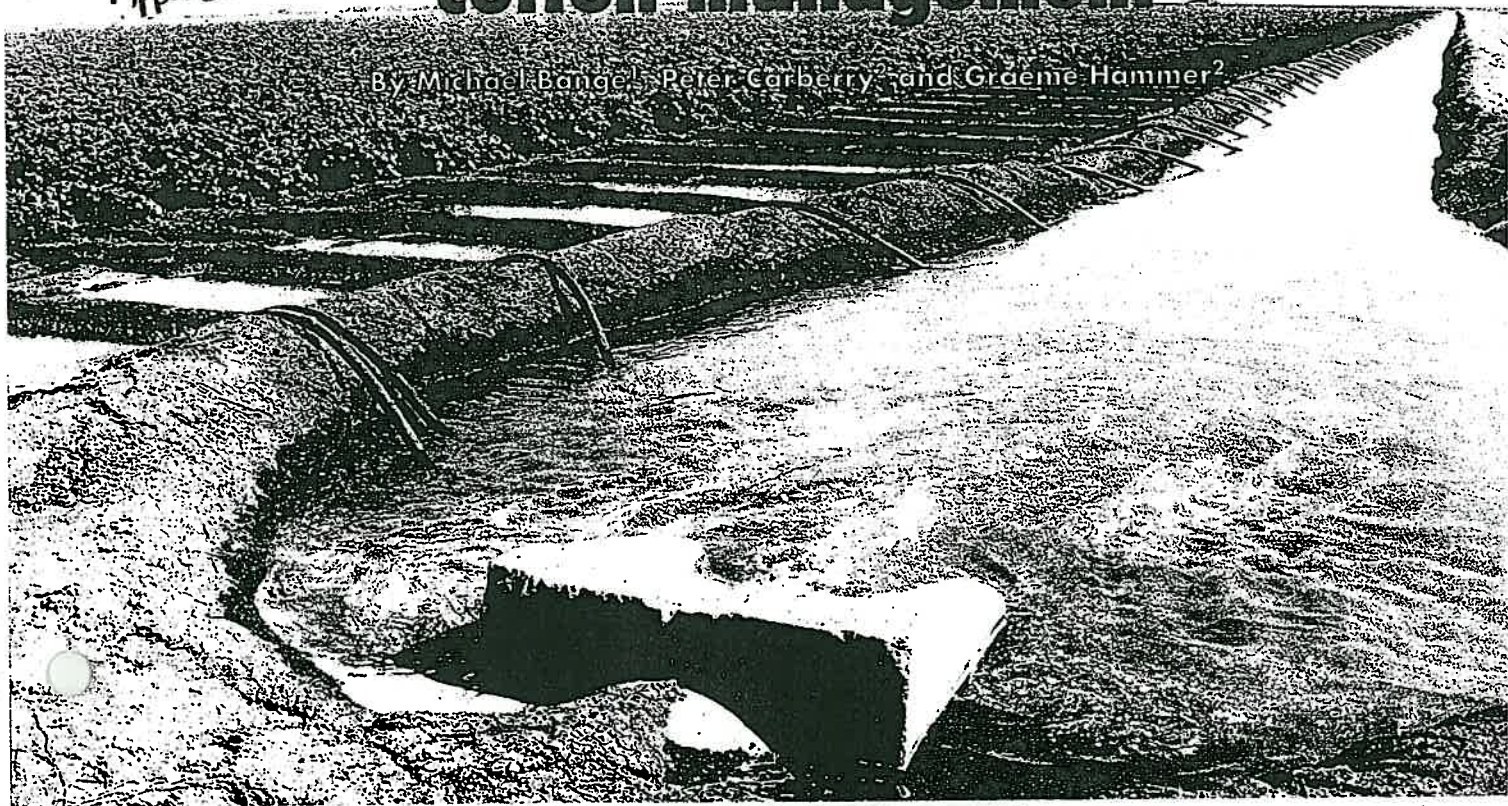

Australian farmers make decisions in the face of large variations in seasonal climate. Managing for the average year runs the risk of achieving low yields in poor seasons or not maximising yield in favourable seasons.

But over the past decade the development of seasonal climate forecasts, based on the El Niño Southern Oscillation (ENSO) phenomenon has introduced the possibility of allowing for climate variability, rather than passively accepting the risks it generates.

Adjusting management in the light of probable future weather trends offers considerable opportunities for managers of agricultural systems.



Michael Bange.

In this article we discuss some uses of seasonal forecasting, in particular using the SOI, and give examples for manage-

ment of both dryland and irrigated cotton production.

## USING SEASONAL FORECASTS

A useful way of interpreting seasonal forecasts is by identifying similar years in the climate history for the site of interest. Seasonal patterns in 'similar' seasons can be used as a guide for the potential risks and outcomes for the seasonal forecast. Outcomes of management decisions can then be assessed in terms of rainfall probability, average yields and the risks associated in achieving these yields for the coming season.

## The SOI

While there are a number of ways of grouping similar years, one of the most successful approaches for partitioning historical records has been using the Southern Oscillation Index (SOI). The SOI is an index of the difference in atmospheric pressure between Darwin and Tahiti. It is a key indicator of the ENSO phenomena.

At present, we divide seasons into five groups, depending on the value and the rate of change of the SOI (SOI phase) at the time of forecast. The SOI phase is derived from the change in the SOI from last month to the SOI value at the time of the forecast:

- Phase I — SOI is consistently negative;
- Phase II — SOI is consistently positive;

38 ▷



## BRUCE GUNNING & ASSOCIATES

No. 1 for service and all your Real Estate needs

94 Balo Street, Moree, 2400

Phone (02) 6751 1133 — Fax (02) 6751 1144

- Licensed Auctioneer • Real Estate Agent • Stock & Station Agent •
- Registered Valuer • Land Agent • Property Management •

*Specialising in Irrigation Sales & Valuations*

### AFTER HOURS:

Valuations and Rural Sales:  
Bruce Gunning 0418 667 831  
Rural Sales:  
Tim Lyne 018 657 174  
or (02) 6752 4164

Residential Sales:  
Kate Bellhouse 019 994 071  
Admin/Property Management:  
Susie Deery (02) 6752 7128

Queensland Sales:  
Stan Wallace (07) 3379 5714  
or 0411 888 237

rapidly rising and zero. But single skip was just as good if the SOI phase is rapidly falling or negative. Double skip was lowest across all phases.

The average yields for each of the SOI phases can be translated into gross margins (Figure 3).

**SOI helps planting decisions**

In this specific example for Dalby (where the crop was sown into half a profile of moisture) there appears to a significant financial advantage in sowing single skip when the SOI phase is constantly negative or falling at sowing.

When the SOI phase is positive, rapidly rising or zero there is no clear advantage in sowing either solid or single skip. In this example there seems to be no advantage in sowing double skip.

In addition to row configuration other management options to reduce risk or seize opportunities could be considered. One of these is nitrogen fertiliser management. In those years where the SOI phase is consistent with potentially higher yields more nitrogen could be applied to take advantage of the opportunity. Conversely,

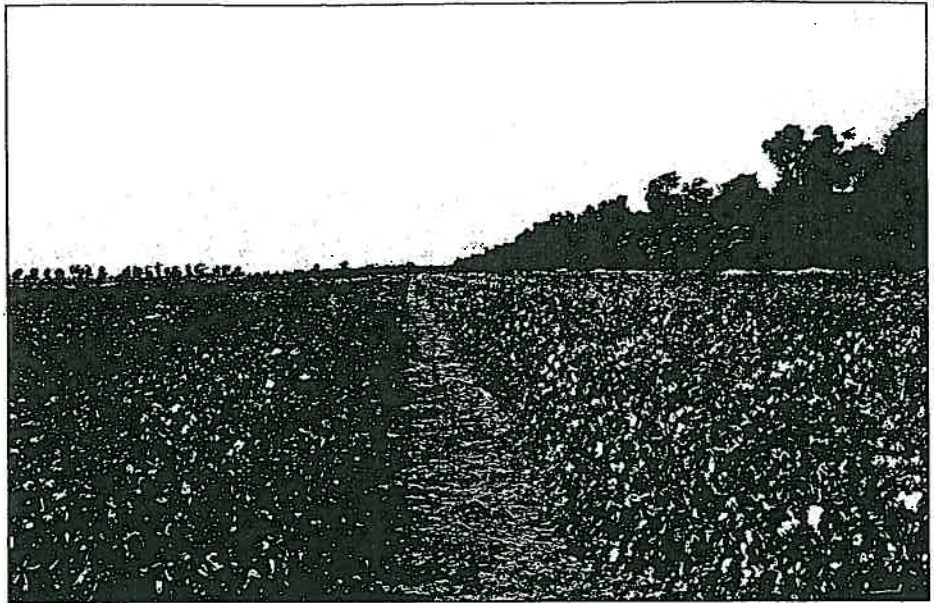

SOI information could be used to make better nitrogen decisions.

when the conditions were less favourable, lower inputs of fertiliser may reduce possible financial losses.

It is important to note that this example is not a general recommendation for selecting row configurations at Dalby. The outcomes and interpretation may change

depending on a number of farm specific factors. These include soil water holding capacity, starting soil moisture and costs.

Most benefit comes from simulating growers' specific conditions using their own soil type and costs. In this example we also only considered potential yield, and not other potential benefits of skip row such as improved fibre quality.

**IRRIGATED COTTON PRODUCTION**

In contrast to dryland cotton production the effects of variability in seasonal rainfall in irrigated cotton production are buffered to a varying degree by allocations of irrigation water. When allocations are poor, rainfall becomes important in maintaining high yield potential, even for irrigated growers.

In this example, yields were estimated using OZCOT for a crop sown in early October in Emerald with different starting allocations of water. Then estimates of yield for each year in the climatic record were categorised into the five SOI phase

42 ▷

**FIGURE 3: Predicted average gross margins for different row configurations with half a profile of soil moisture at sowing in Dalby for different phases of the SOI**

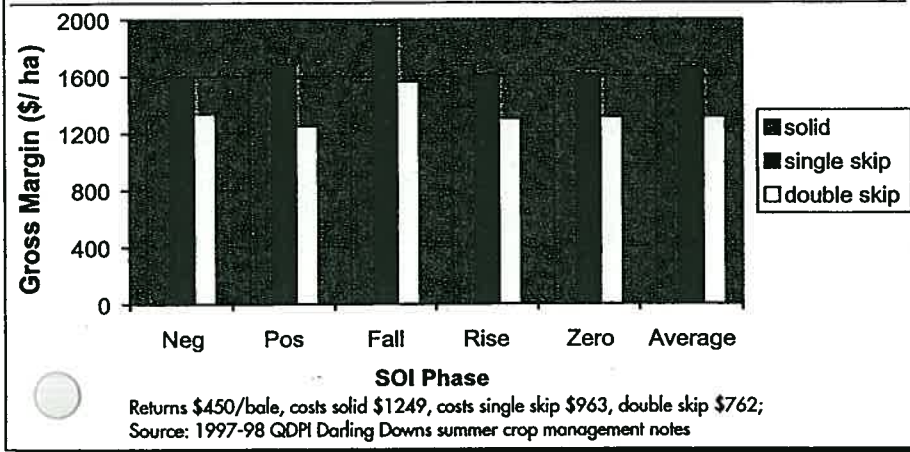

# BIG cottoN.

Maximise yield, minimise effort with **BIGN**, the most efficient way to deliver nitrogen to your soil.



INS115

## Monitoring nitrogen and soil water:

# Deep soil sampling benefits dryland cotton

By Dirk Richards<sup>1</sup>, Michael Bange<sup>1</sup>, Neil Dalglish<sup>2</sup> and Shayne Cawthray<sup>2</sup>

**N**itrogen and soil moisture are two important factors influencing the potential yield of dryland cotton. Deep soil sampling can provide information about the location and quantity of plant available nitrogen and the soil moisture profile.

Deep soil nitrogen tests have found over 350 kg per hectare of available nitrogen under some northern NSW dryland cotton crops. Knowing more about the status of the soil can help farmers and advisers make more informed decisions about fertiliser and crop management — maximising crop yields while reducing production costs.

Researchers from the Cotton CRC and the Agricultural Production Systems Research Unit (APSRU) have been working together with dryland cotton growers and their consultants. They have been helping them gain a better understanding of their soil resource and how their crops react to varying conditions. This research has helped develop simple and inexpensive equipment and methods to allow frequent monitoring of the soil moisture and nitrogen status of a soil.

## NITROGEN MONITORING

Nitrogen is important for crop development and yield. Low levels of available nitrogen mean the crop will set fewer bolls — reducing yield and affecting fibre quality. Too much nitrogen will promote rank vegetative growth, resulting in delayed maturity and an unmanageable plant that is difficult to harvest.

Knowing how much is available to the

crop can provide opportunities to modify nitrogen fertiliser management strategies. This allows growers to take advantage of potentially good seasons by applying more fertiliser and reducing financial losses in poor seasons by applying less.

In the past many dryland growers sampled the surface layers of the soil and made nitrogen fertiliser decisions based on this. Sampling to a greater depth (at least to 90 cm but preferably deeper) is recommended to obtain the complete picture.

Not only will this information be useful to assess nitrogen fertiliser requirements but it can also be used to evaluate the effectiveness of nitrogen fixing legumes and other crop rotations. Deep soil sampling can also be used to identify other factors such as soil water content, root penetration, salt content and pH — which may affect water availability and nitrogen uptake.

## NITROGEN BULGES

Deep soil sampling has given many dryland growers an insight into the effect of their fertiliser strategies on soil fertility. One common finding has been the identification of 'nitrogen bulges'. Many soil samples on both the Darling Downs and in northern NSW have identified over 300 kg per hectare of available nitrogen to a depth of 1.8 metres.

In one case a farmer in northern NSW growing dryland cotton with a wheat rotation found 380 kg per hectare of available nitrogen in the profile. This deep soil sampling prior to sowing found a nitrogen 'bulge' at 90–150 cm depth which the

**FIGURE 1: Soil nitrogen profiles to 180 cm depth, showing levels at sowing and at harvest**

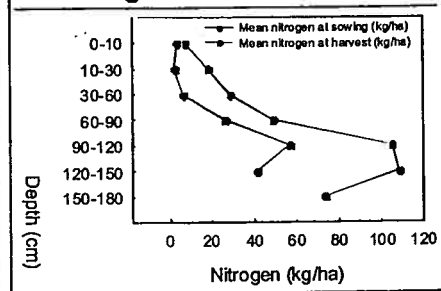

cotton crop could potentially use (see Figure 1). From this the grower was able to reduce his nitrogen inputs, take advantage of the soil's store and lower his costs.

Following a successful crop of 4.9 bales per hectare, deep soil sampling at harvest showed that the cotton crop had used almost half of the nitrogen that was found in the bulge and 250 kg of the total soil nitrogen.

## THE BENEFITS OF MONITORING SOIL WATER

Knowing how much moisture is being stored in the soil and what is available to the crop is valuable information that enables:

- Better estimates of potential crop yields;
- Matching of inputs to potential yield — for example nitrogen rates;
- Selection of crops and varieties (for example whether to sow sorghum or choose cotton), allowing realistic assess-

60 ▷

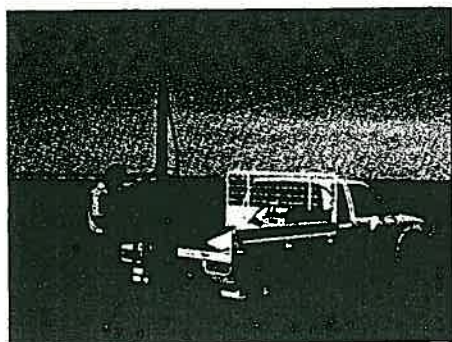

Photo 1: Soil core equipment mounted on a vehicle allows easy sampling across a field.



Photo 2: A pond being installed to determine the drained upper limit.

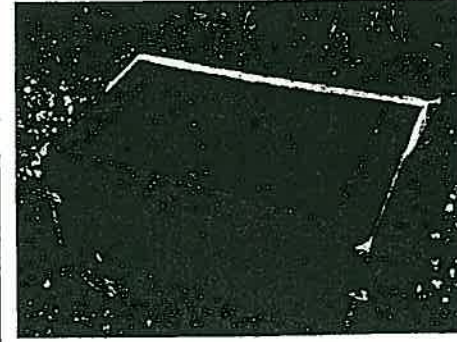

Photo 3: Tent erected in a single skip cotton crop.

estimates of soil water at the start of the fallow and optimistic estimates of fallow efficiency. While this method should be considered as a last alternative, soil coring could help to improve its accuracy by sampling at the beginning of the fallow.

The growers concluded that soil coring gave the most accurate measurement of PAWC although it was the most expensive option. They decided it was better to use the push probe in conjunction with the soil corer — using the soil samples to better calibrate the push probe. They also acknowledged that the added advantage of coring was that samples could be taken deeper in the profile and across paddocks to give reliable estimates of soil moisture, and for soil nutrient analyses.

Ultimately, if growers have an estimate of soil moisture levels, they can begin to maximise production by using this information to refine their management and reduce risk.

Following deep soil sampling prior to sowing on his Edgeroi property, dryland cotton grower Andrew Campbell was able to confidently sow single-skip cotton. We know that he had given his crop the best chance of succeeding with a near full profile following a long fallow. The subsequent post-harvest soil sample showed that the

dryland crop had used nearly all of the plant available soil moisture.

### HOW CAN SOIL CHARACTERISATION BE USED WITH CROP SIMULATION TO HELP FARMERS?

The computer simulation models, OZCOT and APSIM, use historical weather data, basic soil parameters and defined crop management options to give estimates of potential crop yields. These models, used in conjunction with accurate measurements of soil water and nitrogen just prior to sowing, can be used to compare alternative agronomic management options (for example sowing time), different crops and rotations.

Over the past six years, a number of commercial dryland cotton crops have been monitored to test the accuracy of these model simulations. Results to date indicate that they can account for at least 70 per cent of observed variation in crop yield. In some crops where simulations were inaccurate, factors such as severe insect damage and poor weed control were shown to be the cause of variation from the measured yields. These elements are not accounted for in the models.

Once growers have confidence in the models and are aware of their limitations,

they can begin to explore how computer simulation can help improve their crop management and reduce the risk of crop failure. The simulations can be used to:

- Explore different crop management options — for example changing nitrogen rate, planting density or variety;
- Explore the yield potential with different soil moisture levels at sowing;
- Simulate last season's crops to see whether they reached their potential; and,
- Help make decisions regarding the current or upcoming crop, based on knowledge about pre-plant soil water, soil analysis results and seasonal climate forecasts.

Using this information, the models can provide an assessment of expected crop performance and economic returns.

### CASE STUDY

A dryland grower at Brookstead (Darling Downs) had good rainfall in December 1998. At this time his profile was half full and contained 340 kg per hectare of available nitrogen to a depth of 1.8 metres.

As both sorghum and cotton prices were reasonable he was unsure of which crop to grow. He could long fallow through to cotton the following season or plant sorghum now and have a short fallow through to cotton.

# ELLIS RUDBALL

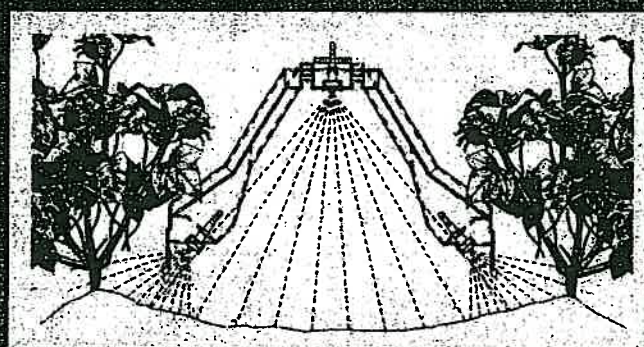

 **ELLIS EQUIPMENT**

100/12/13/14/15/16/17/18/19/20/21/22/23/24/25/26/27/28/29/30/31/32/33/34/35/36/37/38/39/40/41/42/43/44/45/46/47/48/49/50/51/52/53/54/55/56/57/58/59/60/61/62/63/64/65/66/67/68/69/70/71/72/73/74/75/76/77/78/79/80/81/82/83/84/85/86/87/88/89/90/91/92/93/94/95/96/97/98/99/100/101/102/103/104/105/106/107/108/109/110/111/112/113/114/115/116/117/118/119/120

## Making informed summer dryland cropping decisions

By Dirk Richards<sup>1</sup>, Michael Bange<sup>1</sup>, and Shayne Cawthray<sup>2</sup>

1. CSIRO Cotton Research Unit, Australian Cotton Co-operative Research Centre (Cotton CRC), Narrabri
2. CSIRO Tropical Agriculture, APSRU, Toowoomba

Australia experiences variable and at times unpredictable weather conditions, and farmers make decisions in the face of large variation in seasonal climate. Managing for the average year runs the risk of achieving low yields in poor seasons or not maximising yield in favorable seasons. The development of seasonal climate forecasts, based on the *El Niño* - Southern Oscillation (ENSO) phenomenon, has introduced the possibility of managing climate variability, rather than passively accepting the risks it generates.

The computer simulation models, OZCOT (CSIRO Plant Industry) and APSIM (Agricultural Production Systems Research Unit), use historical weather data, basic soil parameters and defined crop management options to estimate potential crop yields. These models can simulate the growth of crops for every season in a historical climate record with identical starting conditions for every season, (e.g. starting soil moisture). Farmers can use the Southern Oscillation Index (SOI) to assist with forecasting seasonal climatic conditions. These forecasts combined with information derived from crop simulation models and a good understanding of the soil condition (e.g. starting soil moisture and nitrogen) can be used to assess the level risk of different summer cropping decisions. This information will complement other information sources such as past local experience, marketing forecasts and time constraints, and other management considerations.

Presently seasons are divided into five groups, depending on the value and the rate of change of the SOI at the time of forecast. These groups are Phase I – SOI is consistently negative; phase II – SOI is consistently positive; phase III – SOI shows a rapid fall; phase IV – SOI shows a rapid rise; phase V – SOI is consistently near zero. At the time this article was written (Sept 1999) the SOI phase was phase V 'consistently near zero'. The simulation models mentioned above were used to simulate the yields of five different crops for full and half starting soil moisture conditions. Different planting configurations for cotton were also considered. Yields were predicted for each season in the climate records for Gunnedah, Bellata, Croppa Creek and Dalby. For those seasons in the climate records that had a near zero SOI phase in September preceding the summer growing season, crop yield averages and the variability encountered were then calculated.

	NSW	QLD
Cotton solid plant	Sown 15 <sup>th</sup> October	Sown 15 <sup>th</sup> October
Cotton single skip	Sown 15 <sup>th</sup> October	Sown 15 <sup>th</sup> October
Cotton double skip	Sown 15 <sup>th</sup> October	Sown 15 <sup>th</sup> October
Sorghum	Sown 22 <sup>nd</sup> October	Sown 15 <sup>th</sup> October
Maize	Sown 22 <sup>nd</sup> October	Sown 1 <sup>st</sup> October
Mungbean	Sown 15 <sup>th</sup> December	Sown 15 <sup>th</sup> October
Sunflower	Sown 15 <sup>th</sup> October	Sown 15 <sup>th</sup> September
Soil type and plant available water capacity	Brigalow, 290mm	Waco, 260mm
Starting soil nitrogen levels to 1.8m depth	200kg/ha	200 kg/ha

Table 1. Simulation details.

The potential yield distributions are presented below, with the blue bar indicating the average yield and the black vertical bar indicating the variability within the yield predictions over the last 100 years for 4 locations.

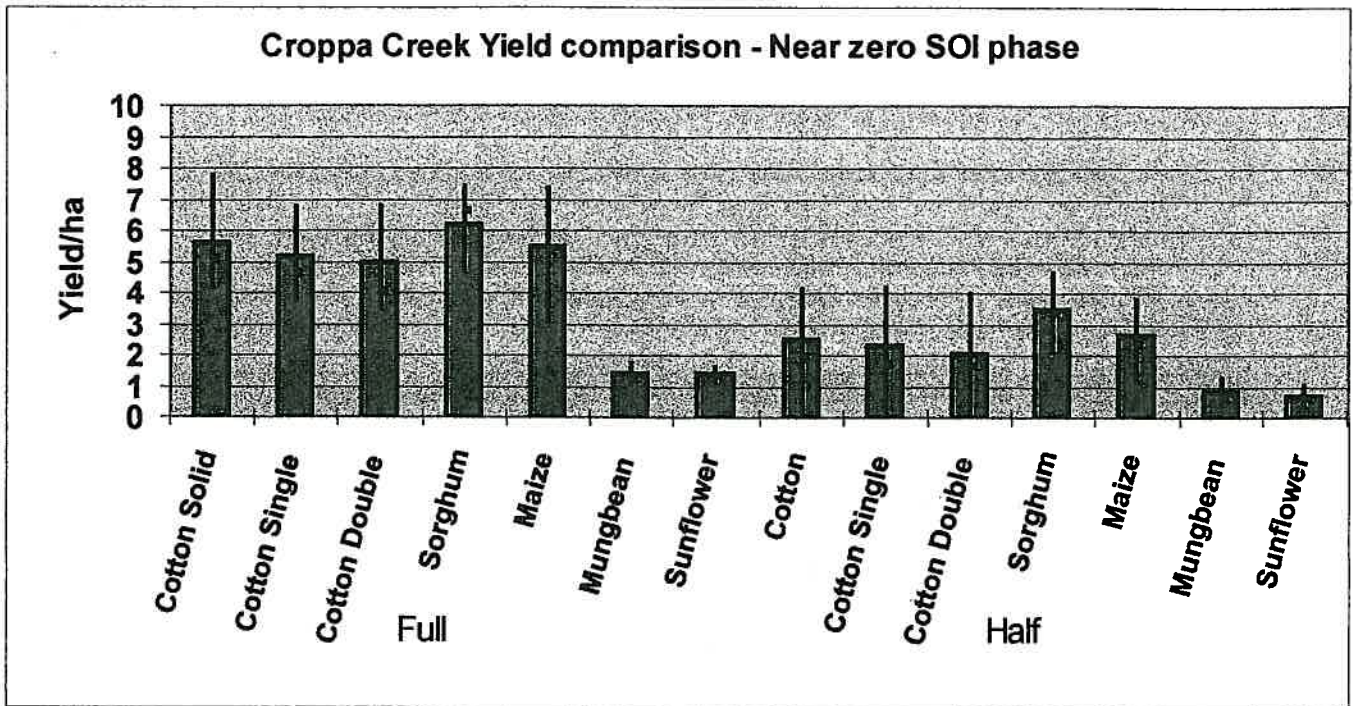

Figure 3: A graph showing forecasted average and variability of dryland yields (simulated using OZCOT/APSIM) with a full and half profile of soil moisture at sowing in Croppa Creek for a near zero phase of the SOI (July-Aug).

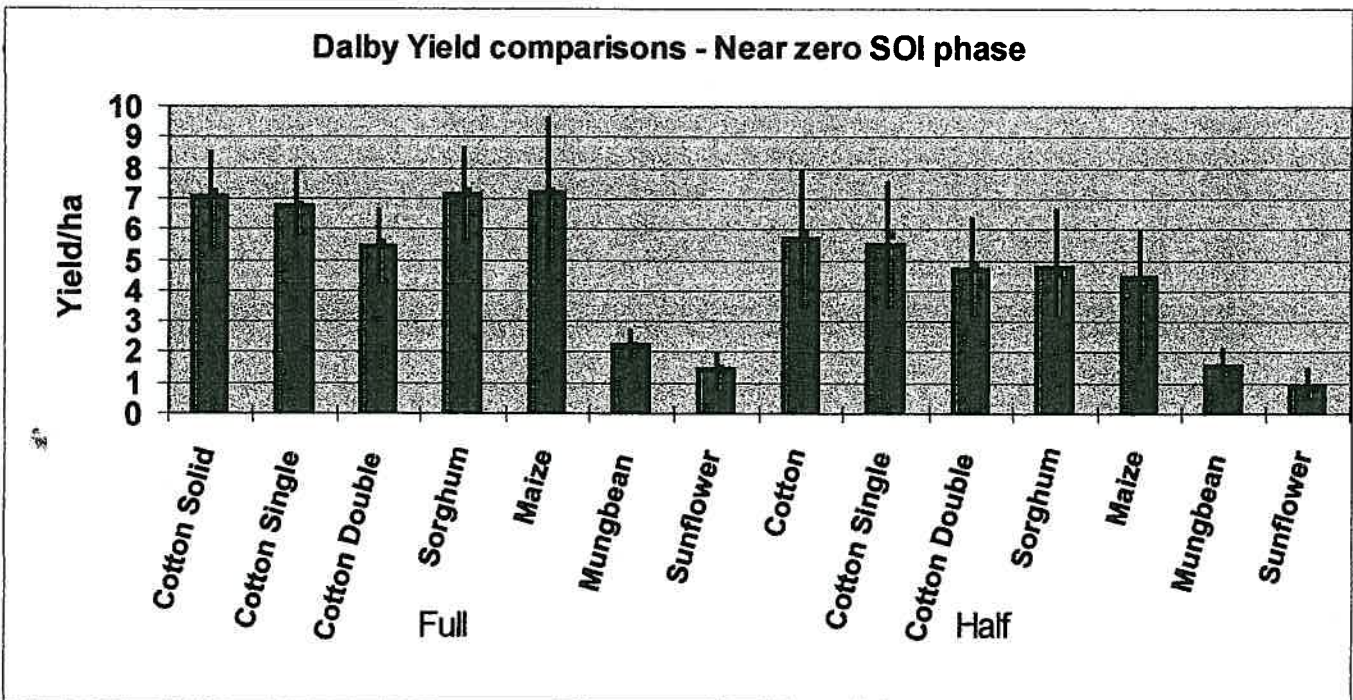

Figure 4: A graph showing forecasted average and variability of dryland yields (simulated using OZCOT/APSIM) with a full and half profile of soil moisture at sowing in Dalby for a near zero phase of the SOI (July-Aug).

# Where did all the sunshine go?

By Dirk Richards, Michael Bange and Steve Milroy  
 Australian Cotton CRC, CSIRO Cotton Research Unit, Narrabri

All cotton farmers are aware of the impact weather can have on their crops and ultimately the profitability of their farming enterprises in any one season. This season has been especially interesting because of the high variability of weather conditions — noticeably the low temperatures experienced in many regions as well as cool conditions followed by exceptionally high temperatures.

## THE 1999–2000 SEASON IN REVIEW

Figure 1 presents an analysis of weekly accumulated day degrees from September 1 to April 16, for 10 locations across the cotton belt. It is important to remember that the variation from the long-term average can often be misleading (see Figure 1). This is because in any one year temperatures will be variable, but the process of averaging over a long period will remove this variability and smooth the long-term average line.

For September and October all locations experienced normal or above average temperatures (day degree accumulation), providing reasonably good starting conditions for young cotton seedlings. But relatively cool conditions prevailed from the end of October until early January, at sites including Narrabri, Bourke and those to the south. These conditions continued until March for sites to the north. In some cases the measurements were well below the long-term averages.

On occasions, warmer than average weeks were also recorded during this period. All locations except Emerald experienced peaks of high temperature during the weeks December 10 to 16, January 22 to 28 and February 12 to 19.

The tail end of the season produced conditions closer to the average, with some sites having accumulated day degrees measured above average for this time of year. The comment by many that “we’re getting January’s weather in March” was not that far from the mark.

A mild start to the season was also reflected in an analysis of the number of cold shocks experienced in any given week for the season (Figure 2). The initial dip in cold shocks corresponds with the above average day degree accumulation in Octo-

26▷

**FIGURE 1: Total weekly accumulated day degrees for the period September 1999 to April 2000**

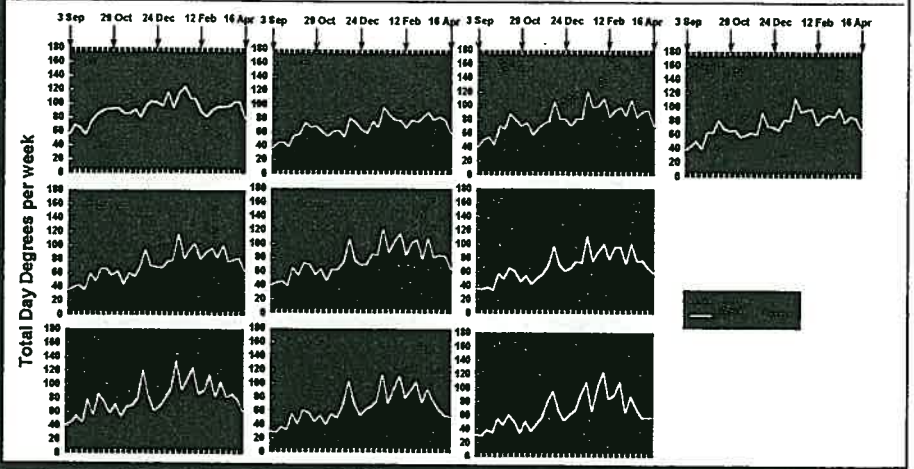

**FIGURE 2: Frequency of cold shocks in each week from September 1999 to April 2000**

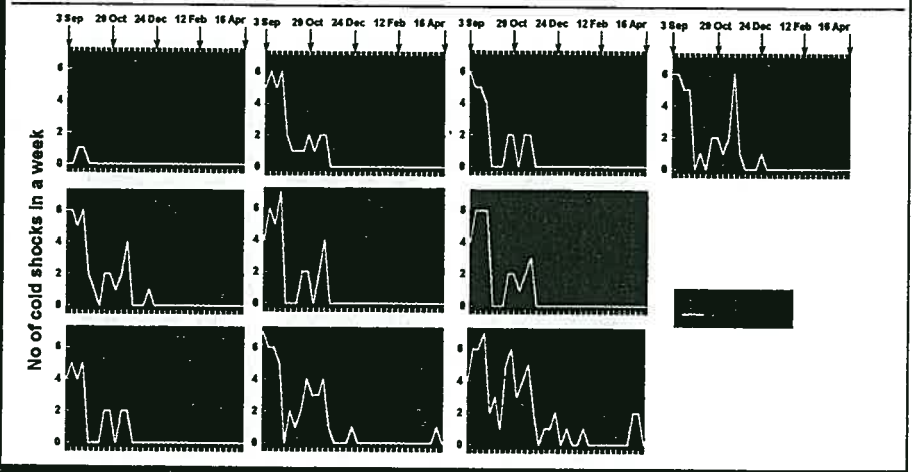

**FIGURE 3: Frequency of hot temperatures each week from September 1999 to April 2000**

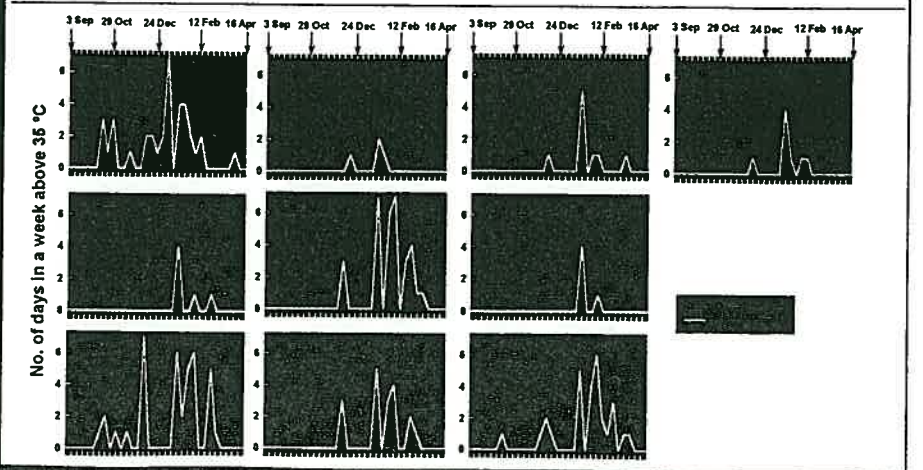

An overall assessment of the season (Table 1) reveals that in most locations, weather conditions were consistent with a cooler, periodically wet growing season, similar in many ways to the 1998–99 season. All locations had below average day degree accumulation and numbers of days above 35°C. With the exception of Goondiwindi, the number of cold shock days was also less than average. Queensland locations received rainfall not too dissimilar to average. But all New South Wales sites received higher amounts — twice the average in the case of Bourke and Hillston.

### REVIEW OF THE SEASONAL FORECASTS

Starting in June 1999, the Southern Oscillation Index (SOI), began a roller-coaster ride. It began consistently positive, rose rapidly in July, followed by a rapid fall in August, before settling into a consistently positive or near zero phase for most of the cotton season. Not the sort of forecast that makes cropping decisions and planning easy.

The climate forecasts based on the SOI, Sea Surface Temperatures (SST) and other predictive climate parameters indicated a 50 per cent or higher probability of exceeding the median rainfall in the months leading up to December, with a very weak La Niña condition developing.

Cooling of waters in the eastern tropical Pacific Ocean during November caused the La Niña pattern to intensify, indicating a greater potential for above average rainfall. Forecasts for the January to March period were for a 60 to 65 per

**FIGURE 4: Monthly rainfall received between September 1999 and April 2000 compared with the long term average**

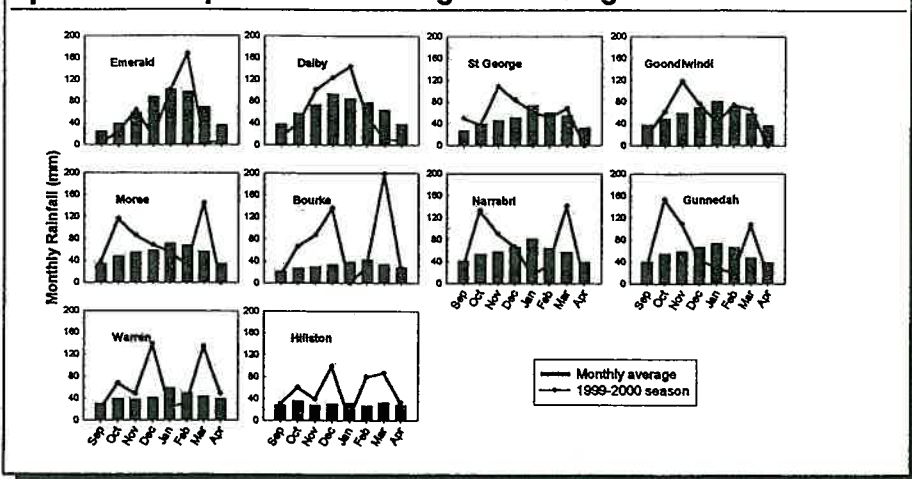

cent chance of above median rainfall for many of the cotton growing regions.

In February 2000 the Bureau of Meteorology also issued their first seasonal temperature forecast. These forecasts predict the average maximum and minimum temperatures for a three month period — not individual weeks, which may vary greatly from the average. The first forecast indicated only a 25 to 35 per cent chance that daily maximum temperatures would be above normal, and a 70 to 80 per cent chance that minimum temperatures would also be above normal.

It is hoped that growers can use information presented in this article to explain their cotton's performance during the 1999–2000 season, and help develop risk strategies to assist with decision making on their farm. This article was the second in a series on topics related to the impacts

of weather conditions on the growth of cotton. For further information about cold shocks, frost and hot temperatures please see the previous article in March–April 2000 issue of *The Australian Cotton-grower*, "Cool Starts: What is normal?"

Growers can also obtain further information about weather and seasonal forecasts from the following sources: Fax services, "Cottonfields" Bureau of Meteorology Farmweather service Web Sites:

<http://cotton.pi.csiro.au/Tools/Weather/>  
<http://www.dnr.qld.gov.au/longpdk/>  
<http://www.bom.gov.au/>



## Did you know that more farmers get loans from us than anyone else?

In the last five years, the National has provided over \$2.7 billion to Agribusinesses across the country, offering tailored solutions to farmers. So if you're considering growing your Agribusiness, then go with the company that more farmers rely on for

their finance. Contact your local National Rural Finance Manager or call 13 10 12.

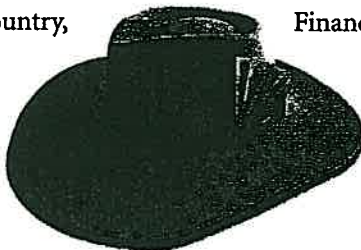

**National**  
 TAILORED FINANCIAL SOLUTIONS

[www.national.com.au](http://www.national.com.au) ©2000 National Australia Bank Limited ABN 12 004 044 937 Patts/N43109/AC

# Cool starts: What is normal?

By Steve Milroy, Michael Bange and Dirk Richards, Australian Cotton Cooperative Research Centre

The cool starts to the past two seasons have again raised awareness of the problems of cold shock and slow crop development rates at low temperature. Low temperatures after sowing increase the time to emergence and reduce seedling vigour.

These factors can lead to poor establishment, poor early growth and increased risk of seedling diseases. In addition they may increase susceptibility to herbicide damage and possibly reduce efficacy of Bt crops. Subsequently, the timing of crop maturity, yield and fibre quality may also be effected.

Staff at the Cotton CRC have received a number of inquiries about the weather we have had so far this season and how this compares to 'normal'.

In this article we present the average day degrees, number of frosts, number of cold shocks, and occurrences of high temperatures for each week during the season from September through to May for locations in the major cotton growing areas. Together with the averages, the highest and lowest values in the climatic record are also presented to give an appreciation of the variation that exists for a particular region.

## DAY DEGREES

In the cotton industry, day degrees are used for a variety of purposes, such as comparing the performance of crops within and across seasons, and for nitrogen fertiliser and pest management using CottonLOGIC.

In terms of development, the day degree calculation used by the industry can give an indication of the amount of development that can be expected on a given day. It is a useful tool for summarising the effect of variation in temperature on development using the daily maximum (Max) and minimum (Min) temperatures. If the daily minimum temperature is above 12°C then day degrees are calculated as:

$$\text{Degree days} = [(Max - 12) + (Min - 12)] \div 2$$

If the daily minimum temperature is equal to or less than 12°C then day degrees are calculated as:

$$\text{Degree days} = (Max - 12) \div 2$$

A base temperature of 12°C is used in this calculation and is the extrapolated temperature at which cotton crop development ceases. But note, that this is not

TABLE 1: Dates of first and last frost for cotton production

Region	Years of climate data	Average date of last frost	Average date of first frost	Date of latest frost recorded	Date of earliest frost recorded
Emerald	111	13 Aug	9 Jun	4 Nov	23 Apr
Dalby	111	8 Sep	26 May	18 Oct	17 Apr
St George	43	21 Aug	7 Jun	3 Oct	7 May
Goondiwindi	107	25 Aug	2 Jun	17 Oct	23 Apr
Moree	111	6 Sep	28 May	22 Oct	12 Apr
Narrabri	43	14 Sep	25 May	12 Oct	27 Apr
Gunnedah	62	14 Sep	22 May	18 Nov	11 Mar
Bourke	43	17 Aug	12 Jun	19 Oct	10 May
Warren	43	13 Sep	27 May	28 Oct	27 Apr
Hillston	43	14 Sep	17 May	28 Oct	1 Apr

the temperature used to determine cold shocks which is 11°C.

Using day degrees assumes that cotton's potential development is largely a function of temperature. The actual rate of crop development at a given temperature in the field can differ depending on factors such as cultivar, soil condition, pest attack, disease and herbicide damage.

Figure 1 presents the average total day degrees for each week of the cotton season (September through to April). In addition to the averages, the highest and lowest accumulated values on record for a particular week are also shown.

These analyses were conducted using weather data collected over a substantial number of years (Table 1). They highlight the differences in climate between the regions and the degree of variation that can exist within each region and during the season. In southern areas, the day degrees per week increase more gradually in the early part of the season, giving the pattern over the growing season a skewed appearance.

Prior to Christmas, the range of recorded values for any week is very large. For example, in the first week of December at Goondiwindi the average value is 90 day degrees but individual years range between 60 and 130 day degrees. In January, the hottest part of the season, the overall variability is at its maximum. Gunnedah is notable for its smaller variability for any week.

## FROSTS

Cotton requires warm soil conditions for emergence — three days with a mini-

mum soil temperature above 14°C are recommended before sowing. Because of this, frost is less commonly a problem than in some other crops which are planted earlier, but late frosts can occur and result in seedling death.

At the other end of the season early frosts can terminate the crop prematurely, reducing the crop's yield potential. Even before this occurs, most fibre properties are reduced when minimum air temperatures fall below 15°C.

Clearly the risk of frost will vary markedly with location and the severity of the frost (including the number of frosts that occur close together). In this analysis a frost was defined as a minimum air temperature of 2°C recorded in a Stevenson screen which is approximately equivalent to a frost at ground level.

Figure 2 presents the average number of frosts for each week of the cotton season (September through to April). In addition to the averages, the highest and lowest recorded number of occurrences during a particular week are also shown.

Table 1 presents the timing of the last frost (the start of the season) and the first frost (at the end of the season). In many cases the average dates of last and first frost fall outside the normal growing season. This shows up with the very low average frost occurrence in early September.

But the analysis shows that, in most regions, there is a real chance that a frost can occur following planting or approaching crop maturity. Dalby stands out in this

72▷

## FARMING SYSTEMS

## Using Ingard® Cotton in a Low Input Cotton System.

'Arcturus Downs', Springsure

Terry Williams (Arcturus Downs) &amp; David Kelly (Qld DPI/ Australian Cotton CRC)

Dirk Richards (CSIRO/ Australian Cotton CRC), Narrabri

**Background:**

This article is a case study of an Ingard® crop grown at 'Arcturus Downs' this season. Crop modelling tools were used to determine if this result could be achieved in other seasons.

**Crop Details:**

<b>Plant Date:</b>	9 October 1999		
<b>Pick Date:</b>	8 March 2000		
<b>Variety:</b>	Nucotn 37		
<b>Yield:</b>	2.66 Bales/acre (6.57 b/ha)		
<b>Fruit Retention at flowering</b>	88%		
<b>Final Boll Count</b>	105 bolls/m		
<b>Soil Type:</b>	Alluvial Clay		
<b>Irrigation:</b>	Pre Irrigated (Mid September) 1: (6 December) 2: (15 January)		
<b>Rainfall</b>	Oct 30 mm	Jan 110 mm	
	Nov 72 mm	Feb 91.5mm	
	Dec 12 mm	<b>Total</b> 315mm	
<b>Fertiliser Inputs:</b>	N = 200	K = 6	
	P = 14	Zn = 2	
<b>Insecticide Sprays</b>	Nil		

This table shows that this crop achieved a yield close to the district average for irrigated cotton. This is despite the fact that:

1. it received no insecticide sprays
2. it received only 2 in-crop irrigations

This makes for a very impressive gross margin.

**The key to the success of this seasons crop was:**

1. Excellent retention of early season fruit allowed an early cut-out and reduced the need to protect young fruit at the end of the season. The keys to this were low heliothis pressure and Ingard® providing sub-threshold control early in the season.
2. Timely rainfall preventing the crop going into serious stress during its fruiting stage. By early January the crop was beginning to get very dry. Timely rain enabled the profile to be filled and also put enough water in storage to enable another full irrigation in mid January.
3. Insect pressure was generally fairly light early season and increased closer to crop maturity, but overall was possibly average. By early January when the heliothis pressure was getting higher, this crop was cutting out and generally not as attractive.

It is estimated that the total irrigation water used on this crop was about 3.5 ML/ha. Rainfall amounted to 315mm or 3.1ML, giving total water input for this season of approximately 6.6ML.

**Could this be done every year?**

To determine whether this situation could be repeated in other years, the variables for the crop were run through the OZCOT model, developed by the CSIRO Cotton Research Unit. This computer program uses historic weather data, including temperatures and in-season rainfall, agronomic, varietal and soil moisture information to determine yield potential.

It does not take into account yield lost from such things as residual insect damage, picker losses, etc. To give a closer indication of paddock yields experience has shown a reduction of potential yields by 7%.

Simulation of the 1999/2000 crop with the actual irrigation dates gives a yield potential of 7.6 bales/ha, indicating this crop achieved close to its potential. Reducing the soil nitrate level to 150kg N/ha and running the model again gave the same yield potential, indicating some cost savings could have been achieved last season from reduced inputs.

To assess the long term potential of cotton under these conditions, the model was run from 1957 until 2000. Each year, the model planted the crop on the same day with the same agronomic conditions, except that the model calculates a daily soil moisture balance and decides when to irrigate the crop.

The assumptions used when modelling this crop were:

- Planting date - 9 October
- Variety - DeltaPine
- Irrigation Allocation - 3.5 ML/ha
- Pre-irrigated mid September
- Soil Plant Available Water Capacity to 1.8m depth - 200 mm
- 200kg nitrogen

Figure 1 shows the yield potential that could be achieved over the last 43 years. The average yield for this period was 2.84 bales /ac (7.02 bales/ha). As the graph indicates, this varies from 1.3 bales/ac (3.2 bales/ha) to 4.6 bales/ac (11.3 bales/ha), with 7% of years greater than the

- Growers should alter their nitrogen strategies based on seasonal forecasts and projected rainfall, as there is potential in seasons which experience high rainfall, that crops may be limited by nitrogen.

	Number of years	Yield bales/ha	Irrigation (mm)	Number of irrigations	Rainfall (mm)	Total water (mm)
<b>Bottom 30%</b>	13	5.18	232	2.6	397	629
<b>30%-70%</b>	13	6.85	242	2.4	391	633
<b>Top 30%</b>	17	8.56	281	2.9	380	661
<b>Average</b>		7.02	255	3	389	643

*Table 1.* Analysis of crop yields and water received during the season, over 43 years of simulation.

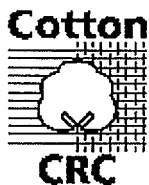

**Delivering to industry the benefits  
of cropping systems models**  
Australian Cotton CRC and CSIRO



**Project Staff:** Dirk Richards, Shayne Cawthray, Michael Bange and Peter Carberry. Technical assistance provided by: Tanya Smith, Graeme Rapp.

- CRDC funded project until June 2001
- Research being conducted in the Lower and Upper Namoi, Gwydir, Bourke and Darling Downs cotton growing areas
- Uses the FARMSCAPE (*Farmers, Advisers, Researchers, Monitoring, Simulation, Communication And Performance Evaluation*) participatory action research technique. This involves facilitation of learning within a grower group rather than researchers acting as “experts” and dictating the groups direction.
- Investigating the delivery of cropping systems simulation technology through existing agribusinesses.

**Key Components**

- Using soil sampling and soil characterisation to help growers, consultants and researchers understand more about the nitrogen and plant available soil moisture components of their cotton growing soils.
  - **Here**, growers and consultants get immediate results and an understanding about their soil.
- Use the nitrogen and soil moisture information as inputs for the crop simulation models, OZCOT and APSIM, to benchmark one fields performance over one season. These models use agronomic, weather, soil moisture and variety information, to simulate the potential growth of a crop. The results are compared with the field-measured yield to assess the performance of their crop.
  - **Here**, growers and consultants can discover their crops real potential, look at the management history, and highlight reasons (in any) for not achieving that potential.
- Using long-term climate information the crop simulation models can predict crop growth and yield with the same sowing conditions, for every year in the climate records. The model will be able to simulate the crop’s growth, experiencing the full range of weather conditions and mimic the impact on crop growth and development over this time, from cold and wet Octobers through to tropical conditions all through the season. An analysis of the results will give long-term crop averages and risks associated with the specific management option. Seasonal forecast such as the SOI (Southern Oscillation Index) can be used to group the years and add value in assessing the risk.
  - **Here**, growers and consultants can use the model output to assess their crops potential yield and risk in any one year based on the SOI and other seasonal forecasts. They can also quantify changes in management, such as timing of first irrigation, variety, or nitrogen application, and comparing the yield potential with their present situation.

# The 2000-01 season in review

By Dirk Richards, Michael Bange and Steve Milroy, CSIRO and Australian Cotton CRC, Narrabri

The season just gone again provided cotton growers with many challenges, including multiple flooding events in various valleys and short periods of extreme hot conditions. In this article we compare the weather over the 2000-01 season from 10 locations to the long term averages. The extreme rainfall events in northern NSW and St George are evident, as are the high numbers of very hot days at these locations and at Emerald during the latter half of the season.

## THE 2000-01 SEASON

Figure 1 is an analysis of weekly accumulated day degrees from September 3 to May 6, for 10 locations within the cotton industry. It is important to remember when using this weekly figure that the variation from the long-term average can often be misleading (see Figure 1). This is because in any one year temperatures will be variable, but the process of averaging over a long period will remove this variability and smooth the long-term average line.

During September and the first week of October all locations experienced normal or above average temperatures (day degree accumulation), providing reasonably good starting conditions for cotton seedlings.

But from mid October until early December, most locations experienced lower day degree accumulation.

This pattern persisted at Emerald until late in December, with day degree accumulation consistently below the long-term averages. The main growing period from December to early March had above average day degrees in Narrabri, Gunnedah, Bourke, Warren and Hillston, with Dalby, St George, Goondiwindi and Moree receiving average conditions.

On occasions, warmer than average weeks were recorded during this period, but these conditions were not maintained. All locations, except Emerald, experienced peaks of high temperatures during the weeks January 22-28 and February 26 to March 4.

The tail end of the season had conditions closer to the average, although many NSW locations had lower day degree accumulation, from March 12 to April 1, which may have delayed maturity in late crops planted in these areas.

## Cold shocks

A warmer start to the season was also reflected in an analysis of the number of cold shocks experienced in any given week

for the season (Figure 2). During early September all locations, except Emerald, had an average incidence of cold shocks compared to the long term average.

Emerald experienced a mild spring, with a reduced number of days with minimum temperature less than 11°C during September. From September 17 to 30 all other locations experienced a sharp reduction in the number of cold shocks, corresponding to higher day degree accumulation during this two week period. The week starting October 1 signalled the return of cold shocks in Dalby, Narrabri, Gunnedah, Warren and Hillston.

Hillston received shocks during the Christmas period (December 24 to 30), similar to events during the 1999-00 season when two cold shocks were experienced in the first week of January. Cold shocks appeared at the end of the season from March 12 onwards in NSW locations. Hillston recorded above average cold shocks for the remainder of the period analysed, while Narrabri, Gunnedah and Dalby had below average numbers. The remaining locations had a generally average number of cold shocks.

42 ▷

FIGURE 1: Total weekly accumulated day degrees for the period September 2000 to May 2001

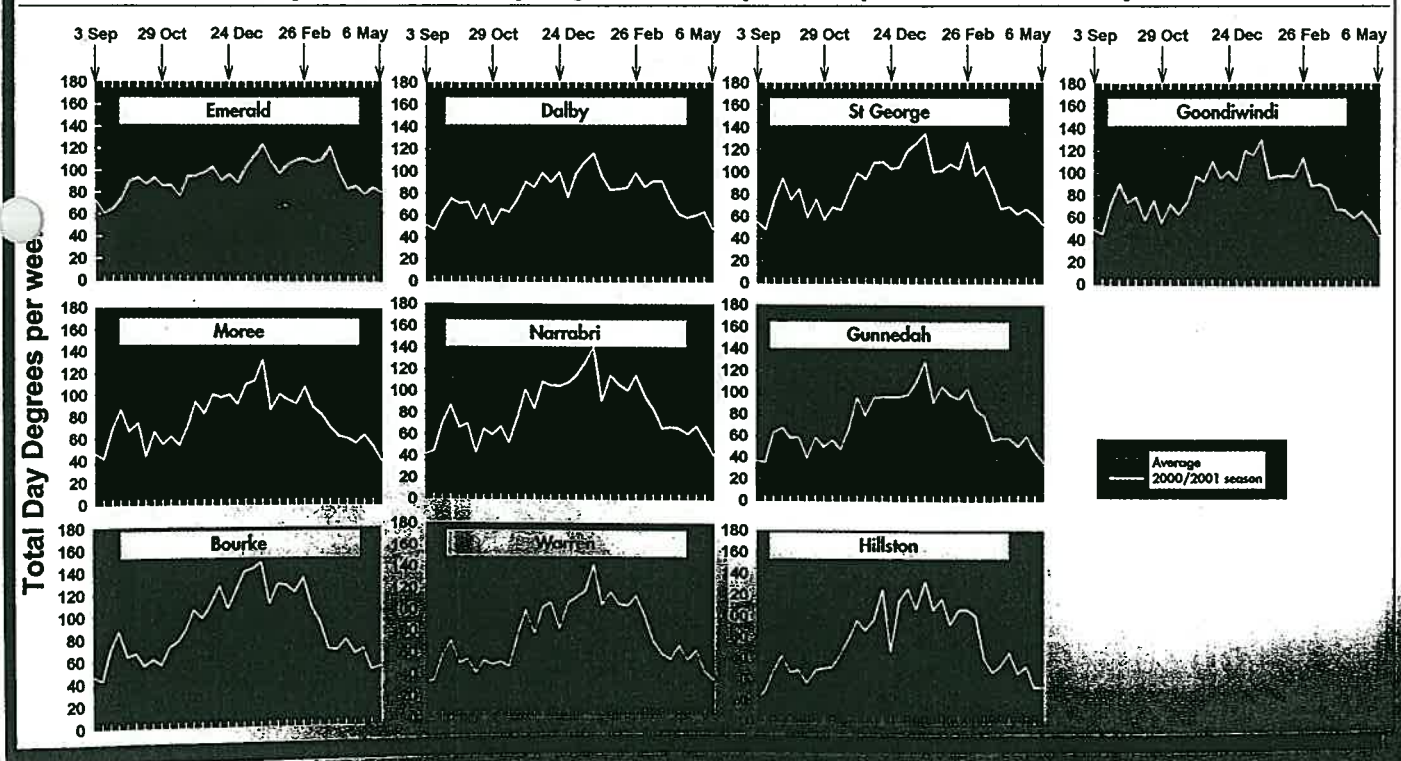

**TABLE 1: Weather conditions during the 2000-01 cotton season (October 1 to April 29)**

Location	Day degrees		Days above 35°C		Cold shocks		Frosts		Rainfall	
	2000-01	Average	2000-01	Average	2000-01	Average	2000-01	Average	2000-01	Average
Warren	2405	2308	50	37	39	36	0	0	426	324
St George	2755	2774	49	54	9	12	0	0	549	382
Narrabri	2617	2441	56	42	23	32	0	0	520	458
Moree	2467	2480	32	33	19	26	0	0	671	423
Hillston	2399	2200	61	38	54	50	0	0	221	230
Gunnedah	2341	2219	26	21	25	31	0	0	593	451
Goondiwindi	2637	2546	37	36	11	16	0	0	468	421
Emerald	2972	2984	51	60	0	2	0	0	291	470
Dalby	2449	2346	29	19	14	19	0	0	417	509
Bourke	2891	2710	89	64	17	19	0	0	294	245

generally corresponded with the weeks with higher day degree accumulation.

**Rainfall**

Monthly rainfall (Figure 4) shows the variability that exists within any season and across valleys. September totals were below or close to average for all the locations. October and November brought St George, Goondiwindi, Moree, Bourke, Narrabri, Gunnedah and Warren well above average rainfall, with resulting waterlogged and flood conditions in these valleys. These conditions may have influenced nutrition in some fields for several

weeks, leading to reduced staple length later in the season.

Late January saw the return of wet conditions in Moree, with Gunnedah experiencing similar events during March leading to delays in picking. These wet conditions are likely to have contributed to fruit loss in some fields. All locations received average or below average rainfall during April. An analysis of long term monthly rainfall at many locations indicates that April is the optimum month for cotton harvest, with a lower probability of significant rainfall events.

An overall assessment of the season (Table 1) reveals that in several locations, weather conditions were consistent with a warmer, periodically wet growing season. Several locations had above average seasonal day degree accumulation and numbers of days above 35°C — factors which could be associated with respectable yields but potentially higher micronaire.

While cumulative rainfall was above average at many locations, the distribution was not as useful as it could have been. Bourke, Hillston and Emerald appear to

44 ▷

Why deal with four different companies when all the services you need can be found in one place?

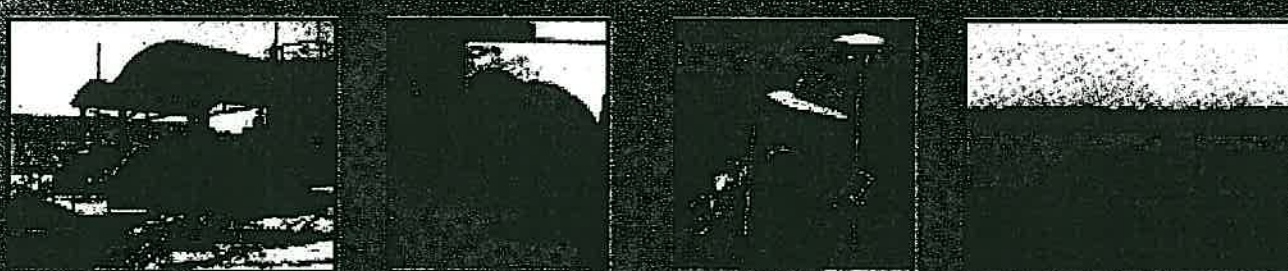

• Planting  
 • Engineering  
 • Preparation design  
 • General maintenance  
 • and more



110-112, 114-116, 118-120, 122-124, 126-128, 130-132, 134-136, 138-140, 142-144, 146-148, 150-152, 154-156, 158-160, 162-164, 166-168, 170-172, 174-176, 178-180, 182-184, 186-188, 190-192, 194-196, 198-200, 202-204, 206-208, 210-212, 214-216, 218-220, 222-224, 226-228, 230-232, 234-236, 238-240, 242-244, 246-248, 250-252, 254-256, 258-260, 262-264, 266-268, 270-272, 274-276, 278-280, 282-284, 286-288, 290-292, 294-296, 298-300, 302-304, 306-308, 310-312, 314-316, 318-320, 322-324, 326-328, 330-332, 334-336, 338-340, 342-344, 346-348, 350-352, 354-356, 358-360, 362-364, 366-368, 370-372, 374-376, 378-380, 382-384, 386-388, 390-392, 394-396, 398-400, 402-404, 406-408, 410-412, 414-416, 418-420, 422-424, 426-428, 430-432, 434-436, 438-440, 442-444, 446-448, 450-452, 454-456, 458-460, 462-464, 466-468, 470-472, 474-476, 478-480, 482-484, 486-488, 490-492, 494-496, 498-500, 502-504, 506-508, 510-512, 514-516, 518-520, 522-524, 526-528, 530-532, 534-536, 538-540, 542-544, 546-548, 550-552, 554-556, 558-560, 562-564, 566-568, 570-572, 574-576, 578-580, 582-584, 586-588, 590-592, 594-596, 598-600, 602-604, 606-608, 610-612, 614-616, 618-620, 622-624, 626-628, 630-632, 634-636, 638-640, 642-644, 646-648, 650-652, 654-656, 658-660, 662-664, 666-668, 670-672, 674-676, 678-680, 682-684, 686-688, 690-692, 694-696, 698-700, 702-704, 706-708, 710-712, 714-716, 718-720, 722-724, 726-728, 730-732, 734-736, 738-740, 742-744, 746-748, 750-752, 754-756, 758-760, 762-764, 766-768, 770-772, 774-776, 778-780, 782-784, 786-788, 790-792, 794-796, 798-800, 802-804, 806-808, 810-812, 814-816, 818-820, 822-824, 826-828, 830-832, 834-836, 838-840, 842-844, 846-848, 850-852, 854-856, 858-860, 862-864, 866-868, 870-872, 874-876, 878-880, 882-884, 886-888, 890-892, 894-896, 898-900, 902-904, 906-908, 910-912, 914-916, 918-920, 922-924, 926-928, 930-932, 934-936, 938-940, 942-944, 946-948, 950-952, 954-956, 958-960, 962-964, 966-968, 970-972, 974-976, 978-980, 982-984, 986-988, 990-992, 994-996, 998-1000

Niño event developing in the Pacific ocean was predicted by several global climate models, with the SOI following suit by changing to a 'near zero' phase. The forecast in early May indicated that the warming of sea surface temperatures in the Pacific had slowed over the previous few weeks, and forecasts from the General Circulation Models still ranged between "neutral" and "El Niño".

The Bureau of Meteorology National Climate Centre issued forecasts during the growing season, with the seasonal temperature outlook for November-January showing probabilities exceeding 50-60 per cent for above average maximum temperatures over much of the cotton growing regions.

These forecasts consider the impact of both the Pacific and Indian oceans and predict the average maximum and minimum temperatures for a three month period not individual weeks, which may vary greatly from the average as shown in Figure 1. The forecast for summer indicated above average maximum temperatures over Victoria, Tasmania, southern NSW and much of South Australia, but most cotton growing regions were predicted to be



**Extremely hot conditions were experienced in January.**

close to the average seasonal temperature. This prediction appears to correspond well with actual conditions experienced, giving some confidence in the Bureau's forecasts.

**INFORMATION SOURCES**

Growers can use information presented in this article to help explain their cotton's performance during the 2000-01 season. This climate information can also help develop risk strategies for better decision making on farm. For further information

about the impact of cold shocks, frost and hot temperatures see the March-April 2000 issue of *Australian Cottongrower*, "Cool Starts: What is normal?" (Vol, 21, No. 2).

Growers can obtain up-to-date day degree calculations by accessing the Australian Cotton CRC web site (<http://www.cotton.pi.csiro.au/Tools/Weather/>) and using the SILO day degree calculator. This tool uses Bureau of Meteorology weather data to calculate accumulated day degree between specified dates.

Further information about weather and seasonal forecasts can also be accessed from the following sources:

**Fax services**

"Cottonfields" Bureau of Meteorology Farmweather service giving detailed forecasts for four days and beyond for key locations in NSW cotton growing regions (Poll fax 1902 935 375).

**Web Sites**

- <http://www.bom.gov.au/> (Bureau of Meteorology)
- <http://www.dnr.qld.gov.au/longpdk/> (The Long Paddock)
- <http://www.cvap.gov.au/> (Climate Variability in Agriculture R&D Program)
- <http://www.bom.gov.au/silo> (SILO)

# CHINA PUMP — MIXED FLOW PUMPS

Vertical Discharge

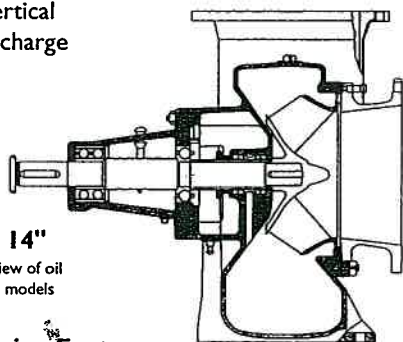

4" — 14"  
Sectional view of oil lubricated models

Horizontal Discharge

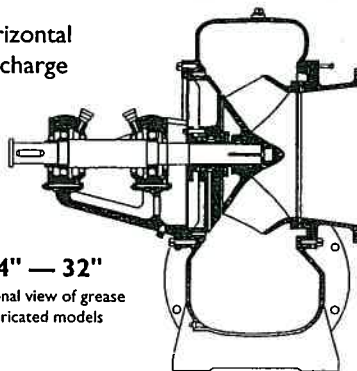

14" — 32"  
Sectional view of grease lubricated models

**Design Features:**

- All models are of horizontal shaft design in two configurations: Vertical and horizontal discharge.
- All models are suitable for vee belt drive or direct coupling.
- All models, with the exception of 26" and 32", have clockwise rotation when viewed from shaft end.
- Provision for water or vacuum priming is included in the pump case.
- All models are available as complete pumpsets with diesel engine, electric motor, PTO tractor drive or shaft drive, and where required, special design modifications and installation details can be provided to suit particular applications.

- Large volume
- Water harvesting
- Re-lift
- Tailwater
- Call us now

Diesel Parts & Service Pty. Ltd. — Pump Division  
21 Hilda Street, Hamilton, Brisbane, Qld 4007  
Phone: 07 3268 1062, Fax: 07 3868 1330

**PHONE (07) 3268 1062**



# CENTRAL QUEENSLAND COTTON TALES



1999-2000

17

8 Jan 2000

DAVID KIELLY DEO Cotton - DPI Emerald

07 49837411

## Reduced Water Late Season- What will it do?

Whilst the Emerald irrigation area will have plenty of water to finish crops off, there are a number of situations around Central Queensland where crops will run short of 1-2 irrigations. This was going to be the case for the Theodore area but recent rains have provided enough moisture to pull most crops through.

**Impact of Cutting Late Irrigations:** The impact of last irrigation on final yield will vary depending on: (1) Boll Load and (2) How Mature The Crop Is when stress is applied, (3) Weather Conditions After the Final Irrigation.

To optimise yield and fibre quality, the soil should reach refill point when the last harvestable boll is mature. Generally the optimum time for last irrigation is when the crop is about 20% open.

The following table, in general terms shows the yield declines that may be expected from reducing water at the end of the season. This is obviously assuming that minimal rainfall occurs during this period.

Last Irrigation Timing	% Final Yield
20% Boll Open	100
boll opening initiated	90 - 96
10 day prior to opening	85 - 90
20 days prior to opening	75 - 85

The reason for this yield decline can be explained as follows:

- **One Irrigation Short:** Slight reduction in boll numbers brought about by immature fruit at the top of the plant and 2<sup>nd</sup> and 3<sup>rd</sup> positions not being able to mature. Boll size may be reduced affecting quality (mainly reduced micronaire).
- **Two Irrigations Short:** Boll numbers reduced significantly. Provided the crop does not move into rapid stress, boll size may actually increase due to the shedding of smaller bolls (<14 days old). Significant yield reductions can occur when both boll numbers and boll size are decreased. This can occur in large vegetative crops that come under stress prior to boll opening

**USING CQ DATA:** The previous calculations assumes minimal rainfall following the final irrigation. The OZCOT model (developed by CSIRO) uses long-term weather information, soil, variety and agronomy information to predict potential yield, and can predict the impact of reduced water at the end of the season. It does not factor in yield loss from such things as disease, pests, inadequate nutrition etc, hence the higher potential yield figures. This data shows less impact from reduced irrigation than the table above, indicating that, on average there is a good chance of getting some rainfall in the months of January and February in CQ.

	Emerald	Biloela	Theodore
Full Irrigation (10% open boll)	3.48	3.76	3.56
One Irrigation Short (10 days prior open boll)	3.36 (96%)	3.68 (98%)	3.44 (97%)
Two Irrigations Short (25 days prior open boll)	3.04 (87%)	3.40 (90%)	3.01 (85%)

Impact on Yield (Bales/acre) from reducing irrigation at the end of the season (**AVERAGE OF ALL YEARS**).

At the present we are in a consistently positive Southern Oscillation Index (SOI) phase, generally indicating average or better rainfall in the next 3 months. The following table shows the impact of reducing end of season irrigation in years with a consistently positive SOI at this time of year.

	Emerald	Biloela	Theodore
Full Irrigation (10% open boll)	3.72	3.88	3.32
1 Irrigation Short (10 days prior open boll)	3.68 (99%)	3.80 (98%)	3.56 (107%)
2 Irrigations Short (25 days prior open boll)	3.48 (94%)	3.70 (95%)	3.76 (113%)

Impact on Yield (Bales/acre) from reducing irrigation - end of the season (**AVERAGE OF +ve SOI years**).

The positive SOI lessens the yield loss of reduced irrigation because of the higher likelihood of rain, and in fact increases the yield potential in the Theodore data.

Thanks to Dirk Richards, CSIRO Narrabri for generating this.

**PIX:** If late applications of growth regulators (ie Pix® are to be used, it is important not to place the crop into any significant water stress for the period after the application. This will in affect impose a **DOUBLE STRESS** on the crop and trials have indicated that it will cause a yield decline.

**FIBRE QUALITY:** The aim of the last irrigation is to ensure that adequate fibre development can be completed on a majority of the harvestable bolls.

If a crop has good early vegetative growth and is stressed post flowering it will usually produce a fibre of slightly reduced length but of high micronaire. This is because stress during early flowering reduces fibre elongation and at the same time causes young boll shed.

Fibre micronaire levels of those irrigated crops suffering late water stress can either be increased or reduced, depending if any significant boll shedding occurs. For these reasons, irrigated crops with high boll numbers and fruit retention (ie **INGARD®** crops) may run a greater risk of micronaire problems if they are subjected to late water stress.

## JASSIDS:

There has been a number of enquiries in the past week regarding thresholds for jassids. These insects feed on leaf tissue, producing a stippling effect, giving leaves a white appearance. Traditionally these minor pests do not cause any problems at this stage of the season as they are controlled by the broad spectrum chemistry used on other insects (eg organophosphates, pyrethroids). For this exact reason there is no industry threshold for jassids post flowering (see Cotton Pest Management Guide 1999-2000, page 49).

This season however numbers have been getting to extreme levels (>400/m) in some crops where broad spectrum chemistry has not been used, particularly Ingard cotton. Unfortunately due to the rarity of excessive damage of this pest, there is little known about the impact it will have on yield or quality. In countries where they are seen in significant numbers (ie Africa), hairy leaf cotton varieties are used to combat the problem however none of the Australian varieties are hairy leaved as this makes the plant more susceptible to mites and heliothis.

It is also unfortunate that control of these pests with currently available products is limited to broad spectrum chemistry. These will decimate predator populations, which still exist in these 'soft' fields and probably keeping a hold on the populations of other secondary pests such as mites and aphids.

From best advice, control should only be warranted if there is excessive damage and extreme jassid numbers. Also consider here the same principals as used in the mite yield reduction equations (see Cotton Pest Management Guide, page 46). In broad terms this suggests the more mature the crop the less likelihood there is for a yield reduction from mite damage.